

DART MOOR

ROCBIRDS MANUAL



TABLE OF CONTENTS

1. Important information and warnings
2. General riding information
3. Dartmoor Rocabirds
4. Geometry
5. Service parts / accessories
6. Suspension settings
7. Rear-wheel assemble
8. Tightening torque
9. External and internal cable routing
10. Maintenance & safety controls
11. List of components



1. INTRODUCTION – IMPORTANT INFORMATION AND WARNINGS

CAUTION: Please read this manual carefully. It contains important safety information.

WARNING: Extreme bicycle ride is a dangerous sport and requires an amazing amount of skills. By engaging in that type of activity user accepts the risk of injury or even death. Even the best bicycle will not help to drop perfectly if the user does not have sufficient skills. Also, the best protection equipment does not guarantee a hundred percent safety. Please note that in this kind of riding, a user can only trust his abilities and must accept the inherent risk. While riding a user can reach significant speeds and therefore face significant hazards and risks. Inspect a bicycle and equipment carefully and be sure that it is in perfect condition before each ride. If possible consult with bike-park personnel, expert riders, and race officials on conditions and equipment advisable. Always wear appropriate safety gear, including an approved full-face helmet, full finger gloves, body armor, bright and visible clothing that is not so loose, that it can be tangled in the bicycle or objects at the side of the road or trail, shoes that will stay on your feet and will grip the pedals (make sure that shoe laces cannot get into moving parts, and never ride barefoot or in sandals). Always use protective eyewear to protect against dirt, dust, and bugs.

WARNING: Some of the service procedures require specialist tools and good mechanical skills. Therefore, to minimize the risk of serious or even fatal accidents, maintenance and assembly work on your bike should be carried out by an authorized bicycle workshop.

WARNING: Failure to maintain, check and properly adjust the suspension system may cause suspension malfunction, in a result of which a user may lose control and fall.

WARNING: Introducing changes in the suspension adjustment can alter the handling and braking characteristics of your bicycle. It is forbidden to change the suspension adjustment unless a user is thoroughly familiar with the

suspension system manufacturer's instructions and recommendations. Users should always check for changes in the handling and braking characteristics of the bicycle after the suspension has been adjusted by taking a careful test ride in a safe area.

WARNING: As with all mechanical components, the frame is subjected to wear and high stresses. Different materials and components may react to wear or stress fatigue in different ways. If the design life of a component has been exceeded, it may suddenly fail possibly causing injuries to the rider. Any form of crack, scratches, or change of color in highly stressed areas indicates that the life of the component has been reached and it should be replaced.

IMPORTANT NOTICE: This manual is not intended as a comprehensive use, service, repair, or maintenance manual. Please consult your dealer for advice and your dealer may also be able to refer you to classes, clinics, or books on bicycle use, service, repair, or maintenance.



2. GENERAL RIDING INFORMATION

Riding a bicycle can be dangerous. Keep this in mind and be cautious at all times. See and be seen. Use lights and reflective clothing in low light conditions. Wearing a helmet when riding can protect the head and save a life. Always conduct a pre-ride check (detailed information can be found further in this manual).

Never ride the bicycle if you observe any technical problems or have any doubts about the proper functioning of any elements in the bicycle. Keep the bike clean and well maintained. It is strongly recommended to carry a pump, spare inner tube, patch kit, and a basic tool kit. It could be required in case of a flat tire or other common mechanical problem. If any doubts or questions ask a bicycle dealer for advice on that issue. If the bicycle is equipped with gears and user can choose a gear combination that is the most comfortable for riding conditions. Gears will allow a rider to maintain a constant rate of pedalling. Use lower gears for going uphill and higher gears for going downhill. Ease up on your pedalling pressure when you shift gears. Ask a bicycle dealer to give more advice on that issue if needed.

Pay attention to the brakes - they can be powerful and if activated too aggressively, may cause a crash. You should spend some time to get a better feel of the brakes on a side road or empty parking lot before the first ride. Avoid riding too fast, especially downhill. It is easy to lose control of the bicycle and crash at high speeds, and also you will find it very difficult to slow down especially if the hill is steep.

If a bike has been equipped with suspension, the increased speed a rider may develop will also increase the risk of injury. For example, the front of the bike may dive on the suspension fork while hard braking. A Rider can easily lose control and fall if he is not prepared for this. Please, learn how to operate your suspension system safely. Thanks to the suspension the wheels can follow the terrain better, which improves control and comfort.

This improved capacity may provide an opportunity for riding faster, but riders should be careful, not to mistake the enhanced capabilities of the bicycle for their riding skills. Improving skills takes time and practice. It is highly recommended to use locks to protect a bicycle from theft. Even if you are planning to be away from a bicycle for just a few minutes never leave your bike unlocked while unattended.



3. DARTMOOR ROCKBIRDS

>>> [Check in our website](#)



ROCBIRD ENDURO PRO



ROCBIRD ENDURO EVO

>>> [Check the Enduro collection](#)

There is a completely new model in the *dartmoor-bikes collection*! Say hello to Rocbird, the successor to the Blackbird and Bluebird frames. With the new frame construction, this enduro/singletrack machine will make climbs easier and descents, even more playful. Rocbird is a lighter frame than the aluminium Thunderbirds so it will take some less beating on the most demanding lines, but on most of the enduro trails you will feel the same riding fun, as Rocbird has the progressive Horst suspension design that works flawlessly, even under heavy braking. Rocbird feels bottomless at the curve's end, allowing both spring and air shocks. The combination of a larger wheel at the front and a smaller one at the rear guarantees perfect handling on all types of trails. To increase rigidity and reliability, we used MAX-type bearings with LLU-type seals in this frame. Thanks to the replaceable shock mount, the Rocbird can be fitted with two sizes of shocks and obtain a frame travel of 160 mm or 140 mm, adapting it to the preferred riding style.

An all-out version of the **new Rocbird Pro** comes with 160 mm of travel based on Fox 36 fork and X2 shock in Factory settings and Kashima bling. Ready to take the beating of rowdy trails and still be light on weight. A full 12-gear Shimano SLX groupset, Shimano SLX brakes, Maxxis Assegai Exo/Exo Plus tires, and a no-shortcuts approach make this bike a no-brainer for trail lovers. Rocbird is taking the best from the idea of the mixed wheels – 29” in the front giving more comfort when riding fast through the rough terrain and 27.5” in the rear as it is more maneuverable and fun especially in tight corners.

The Evo version of the Rocbird Enduro offers a perfect balance between the quality of components and the price of the bike! It's a 160mm-travel machine with the suspension at front provided by the well proven RS Lyrik Select fork with Charger RC damper and at rear by the X-Fusion's new H3A air shock. 11-speed Shimano Deore group is responsible for shifting gears in this bike, and 4-piston Magura MT Thirty brakes for braking. We've also kept in this model the top-level Maxxis Assegai Exo / Exo Plus tires, so no one should be afraid of going with this bike right out of the box straight to the high mountains! Rocbird is taking the best from the idea of the mixed wheels – 29” in the front giving more comfort when riding fast through the rough terrain and 27.5” in the rear as it is more maneuverable and fun especially in tight corners.



ROCBIRD TRAIL PRO



ROCBIRD TRAIL EVO

[>>> Check the Trail collection](#)

Rocbird Trail Pro is all about versatility. Here you will find a Rocbird frame with 140 mm travel, coupled with Fox's top suspension from the performance elite line: 36 fork with 150 mm travel and a Float X shock. A full 12-gear Shimano SLX groupset, Shimano SLX brakes and Maxxis Dissector / Aggressor tires. With such an uncompromisingly equipped bike, you can go wild not only on trails but also on many enduro lines. Rocbird is taking the best from the idea of the mixed wheels – 29" in the front giving more comfort when riding fast through the rough terrain and 27.5" in the rear as it is more maneuverable and fun especially in tight corners.

Rocbird Trail Evo offers a perfect balance between the quality of components and the price of the bike! With a 140mm frame travel and the Rock Shox suspension including Lyrik Select Charger RC fork and Deluxe Select R shock it's a great platform to start your singletrack adventures. 11-speed Shimano Deore drivetrain, 4-piston Magura MT Thirty brakes, and the top-level Maxxis Dissector/ Aggressor Exo/Exo plus tires make this bike the best deal for those who prefer to spend money on trips and adventures. Rocbird is taking the best from the idea of the mixed wheels – 29" in the front giving more comfort when riding fast through the rough terrain and 27.5" in the rear as it is more maneuverable and fun especially in tight corners.



ROCBIRD JUNIOR 27.5/26



ROCBIRD JUNIOR 26/24

>>> *Check the Junior collection*

The kids are alright, and we came up with sweet tooth builds for the promising riders! We understand smaller or „just starting” rippers who demand the best bike birthday money can buy. Rocbird and its Junior versions have updated frame aesthetics as enduro/singletrack machines to make climbs easier and descents even more playful. The new progressive Horst suspension design has been updated for trail geometry, and the mullet wheels setup provides a superb track feeling!

Rocbird Junior is a tailor-made enduro machine for the youngest rolling on a 27.5/26-inch mullet setup. This junior bike with suspension built on proven and truly made for gravity X-fusion components is perfect for watching kids passing you at the bikepark. Rocbird Junior in this size has retained the progressive 160 mm of travel, leaving the young rider full freedom on trail and enduro routes. 11-speed Shimano Deore drivetrain with 11-51T Sunrace cassette and 4-piston Tektro M535 brakes guarantee a great day in the bikepark!

The smallest Rocbird has all the features like the bigger ones, packed in a frame designed for kids 130-145 cm tall. A combination of two wheel sizes (26” and 24”), 130 mm of frame travel, kids-tuned MTB suspension from X-fusion with a 130 mm fork, and brake/shifter levers optimized for kids’ hands – all that is needed to stay calm and keep watching how your little devils grow.



4. GEOMETRY

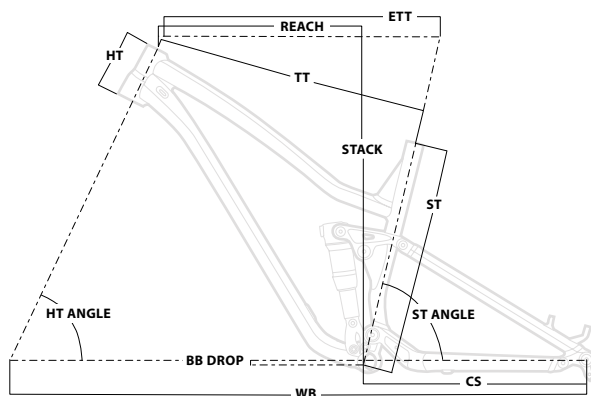

>>> [Check the Enduro collection](#)

Reach: horizontal distance from BB center to HT center
 Stack: vertical distance from BB center to HT center
 ST: seat tube length (BB center to ST top)
 TT: top tube length (actual)
 ETT: top tube length (effective)
 CS: chain stay length
 HT: head tube length
 HT angle: head tube angle
 EST angle: seat tube angle (effective)
 BB drop: bottom bracket height (BB center to WB)
 WB: wheel base

Size	Small	Medium	Large
Reach	430	460	490
Stack	638	638	638
Seat tube	400	420	450
Eff top tube	570	597	628
Chainstay	430	430	430
Head tube	120	120	120
HT angle	64,5	64,5	64,5
ST angle	78	78	78
BB drop	35/16	35/16	35/16
Wheel base	1196	1226	1256
Standover	778	778	778

Size	Small	Medium	Large
Reach	430	460	490
Stack	638	638	638
Seat tube	400	420	450
Eff top tube	570	597	628
Chainstay	430	430	430
Head tube	120	120	120
HT angle	64.5	64.5	64.5
ST angle	78	78	78
BB drop	35/16	35/16	35/16
Wheel base	1196	1226	1256
Standover	778	778	778

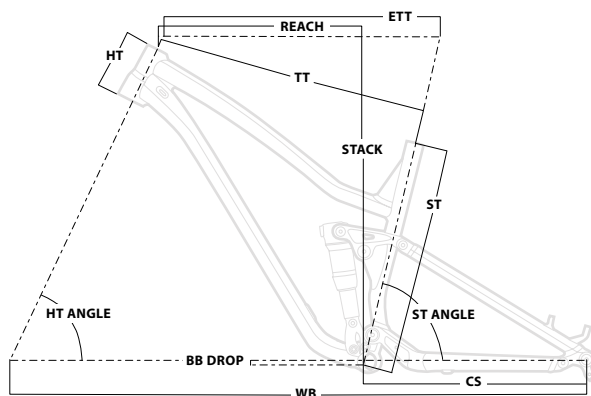

ROCBIRD TRAIL PRO



ROCBIRD TRAIL EVO

>>> *Check the Trail collection*

Reach: horizontal distance from BB center to HT center
 Stack: vertical distance from BB center to HT center
 ST: seat tube length (BB center to ST top)
 TT: top tube length (actual)
 ETT: top tube length (effective)
 CS: chain stay length
 HT: head tube length
 HT angle: head tube angle
 EST angle: seat tube angle (effective)
 BB drop: bottom bracket height (BB center to WB)
 WB: wheel base

Size	Small	Medium	Large
Reach	444	474	504
Stack	628	628	628
Seat tube	400	420	450
Eff top tube	565	594	624
Chainstay	430	430	430
Head tube	120	120	120
HT angle	66	66	66
ST angle	77	77	77
BB drop	36/17	36/17	36/17
Wheel base	1189	1217	1247
Standover	753	753	753

Size	Small	Medium	Large
Reach	444	474	504
Stack	628	628	628
Seat tube	400	420	450
Eff top tube	565	594	624
Chainstay	430	430	430
Head tube	120	120	120
HT angle	66	66	66
ST angle	77	77	77
BB drop	36/17	36/17	36/17
Wheel base	1189	1217	1247
Standover	753	753	753

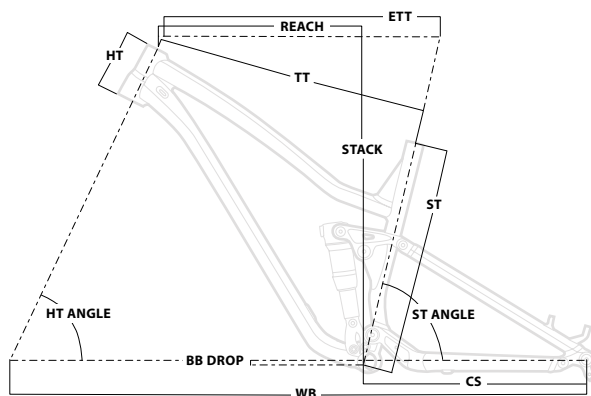

>>> *Check the Junior collection*

Reach: horizontal distance from BB center to HT center
 Stack: vertical distance from BB center to HT center
 ST: seat tube length (BB center to ST top)
 TT: top tube length (actual)
 ETT: top tube length (effective)
 CS: chain stay length
 HT: head tube length
 HT angle: head tube angle
 EST angle: seat tube angle (effective)
 BB drop: bottom bracket height (BB center to WB)
 WB: wheel base

Size	One Size
Reach	400
Stack	628
Seat tube	361
Eff top tube	528
Chainstay	415
Head tube	100
HT angle	64.5
ST angle	78
BB drop	16/15.5
Wheel base	1132
Standover	628

Size	One Size
Reach	375
Stack	565
Seat tube	321
Eff top tube	472
Chainstay	399
Head tube	100
HT angle	66
ST angle	78
BB drop	6/-20
Wheel base	1059
Standover	610

SELECTION OF THE APPROPRIATE SIZE OF THE FRAME TO THE USER'S HEIGHT:

ROCBIRDS

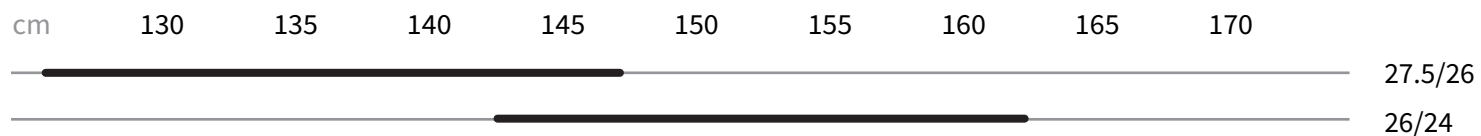

ROCBIRD ENDURO PRO

PDF >>> [Open the document](#)

ROCBIRD ENDURO EVO

PDF >>> [Open the document](#)

ROCBIRD TRAIL PRO

PDF >>> [Open the document](#)

ROCBIRD TRAIL EVO

PDF >>> [Open the document](#)

ROCBIRD JUNIOR

PDF >>> [Open the document](#)

PDF >>> [Open the document](#)



5. SERVICE PARTS

We know how important it is for the user to have a working piece of equipment, especially when enduro riding can be this unpredictable sport. In this regard, we offer a list of dedicated spare parts and service parts to help properly service your Dartmoor-Bikes equipment.

Aluminum Rocker for Rocbird and Rocbird Junior frames

>>> *Check the spare parts*



Bearings set for Rocbird and Rocbird Junior frames



Shock mounts with bolts, for 205x65 mm shock (enduro version) for Rocbird and Rocbird Junior 27.5/26 frames



Shock mounts with bolts, for 185x50 mm shock (trail version) for Rocbird frame



DU bushings set (for chainstay-dropout connection) for Rocbird and Rocbird Junior frames



Rocker-frame connection bolts set for Rocbird, Rocbird Junior, Thunderbird SE and FR



Rocker shock mount bolts for Rocbird, Rocbird Junior and Thunderbirds CF, SE, FR frames



Main pivot axle bolts set for Rocbird, Rocbird Junior, Thunderbird SE and FR frames



Seatstay-rocker and seatstay-chainstay connection bolts set for Rocbird and Rocbird Jr frames



Frame shock mount bolt for Rocbird and Rocbird Jr 27.5/26 frames

Frame shock mount bolt for Rocbird Jr 26/24 frame



ISCG chain device adapter Rocbird and Rocbird Jr 27.5/26 frame



6. SUSPENSION SETTINGS

Tutorial video showing how to set up the suspension on a full-suspension bike.

YT >>> Watch the video

INITIAL SAG

Suspension settings are a matter of personal preference. Some riders prefer a soft setup, others a hard setup. Depending on the riding style, skills, and conditions on the route. The suspension on a trail/ enduro bike works fine with approximately 20% -30% initial sag. For the front shock, the value of 20-25% should be assumed, while for the rear shock the initial deflection should be about 25-30% of the total stroke. Before starting work, set the return damping to the fully open position.

To measure the SAG, follow the instructions/indications below:

- Move the O-ring on the stanchion so it touches the fork seal, the same for the rear shock.
- Stand on the pedals with your full body weight with full equipment: protective armor, helmet, neck protector, water bottle or water bag, etc. It is important that the equipment and clothing reflect the real riding conditions to give the most accurate results. While standing on the bike, bend the suspension several times, then push the O-ring against the shock seals again. It is best to have someone to help, but you can deal with it yourself, for example by leaning against the wall of the building.
- Get off the bike carefully and measure the SAG with a ruler or tape measure printed on the stanchion, or ask someone to read the value on the scale when standing on the bike in a neutral position (slightly bent knees and hands in elbows). Inflate or deflate the damper until the desired deflection of the shock is achieved.

In the case of an ungraduated rear shock, to determine the percentage of initial deflection, its total deflection must first be measured, because it is shorter than those given in the catalog for the total travel of the rear swingarm. To do this, reduce the pressure in the air chamber so that you can bend the shock to its extreme position, then inflate it and measure the distance between the O-ring and the seal. For example, a bicycle with 160 mm travel has a rear shock with 70.87mm deflection, assuming a SAG of 30%, its value measured on the shock absorber piston with correctly set pressure should be 21.26mm ($70.87 \times 0.3 = 21.26\text{mm}$).

REBOUND – return damping (rebound speed)

In the damper return damping setting, the so-called „curb test” works best. To proceed with the adjustment, follow the instructions/indications below:

- Unscrew the Rebound valve to the extreme position, depending on the manufacturer on the casing towards the „bunny” symbol, „Fast” or minus sign. There is no return damping in this position.
- Find a less traveled road in your area with a medium size curb.
- While sitting in the saddle, without using the brakes, slowly descend from the saddle. The damper piston retracts first, then returns to its original position and begins to oscillate until it stops.
- To counteract the “rocking” phenomenon, turn Rebound two clicks towards the “turtle” symbol (+; “slow”) and repeat the test by rolling off the curb. By adjusting in this way, you should observe the moment when the damper stops oscillating after a rebound.
- The resulting setting is the initial setting from which you should start. Further adjustments for two clicks backward or forwards can be made on the trail depending on riding conditions and preferences.

- Remember that, as with the SAG, the return suppression is determined by the weight of the user and all equipment. The greater the weight of the bike user, the greater the damping will be needed to absorb the rebound energy.

It is best to set the front shock return damping as follows:

- Start by unscrewing the damper to the extreme position as it was in the case of the damper. Stand next to the bicycle, depress the shock as far as possible, and release it vigorously. Observe that the front wheel is clear of the ground. Increase the damping by two clicks by using the adjuster on the bottom of the right shock leg, turning towards the „turtle” symbol („+”; „slow”).
- Repeat this process until the wheel stops springing off the ground. The basic setting obtained in this way can be corrected on the trail depending on the driving conditions and individual preferences.
- Finally, get on the bike and on a straight road, vigorously bending the suspension, check that the front and rear work evenly. By pressing the suspension in this way, bend it in the range of 80-90%, if it is difficult, it may turn out that the shock or damper needs to be adjusted in terms of the air chamber capacity. To do this, contact an experienced service provider who will adjust the size of the chamber with the help of tokens.

COMPRESSION – speed of compression (deflection)

Most air shocks have a compression speed damping adjustment implemented by a single knob. It enables smooth or gradual regulation until the shock is blocked. This adjustment is most often used while driving, adapting the shock to the type of route. The fully open position is most often used when descending on uneven terrain when we want the best traction. Slowing down the compression speed to about half of the range is used in normal riding on flat sections and in the case of riding on flow routes so that the suspension does not absorb the user's speed while riding on moguls. This setting is the most used and the most universal, also for people who like to jump on a bike. The shock absorbs energy when hitting a punch, so some riders prefer to increase compression damping.

The extreme setting is the least used, most often when climbing steep climbs.

More advanced designs of the shock, mount a damper with two regulators, fast and slow compression. Slow compression damping acts on the first half of the shock travel, mainly when braking, negotiating steep descents, rides, or moguls. Increasing it improves the efficiency of pedaling, prevents „swinging” and reduces the collapse of the suspension when overcoming the above-mentioned elements. Similar to the case when you have only one compression knob. Therefore, the adjustment is made in the same way.

High-speed compression damping affects the second half of the stroke of the shock from the middle of the deflection to the moment of compression.

Typically, less experienced riders do not use this adjustment and it remains in the open position. Users who like to ride more aggressively, forcing the suspension to work quickly, after hitting a large obstacle will feel that the suspension dives too quickly to the end of the stroke, they can counteract this phenomenon by increasing the damping of quick compression.



REAR SUSPENSION ASSEMBLY

Rocker shock mount:

1. Shock mount rocker bolt – 2 pc.
2. 6900 MAX LLU bearing – 2 pc.
3. Spacer 10x17x2 – 2 pcs.

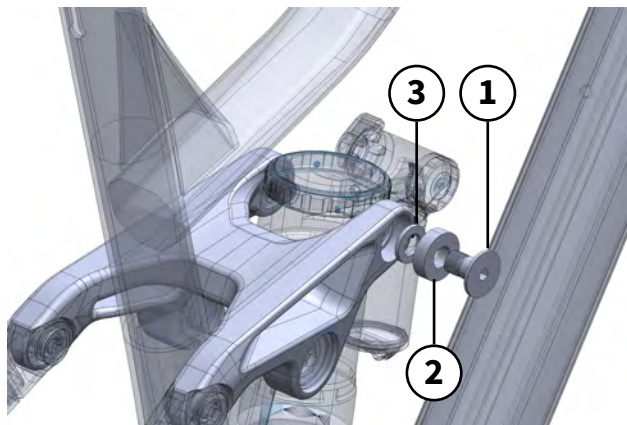

Bottom shock mount:

1. Bottom shock mount bolt – 3 pcs.
2. Bottom shock mount left – 1 pc.
3. Bottom shock mount right - 1 pcs.

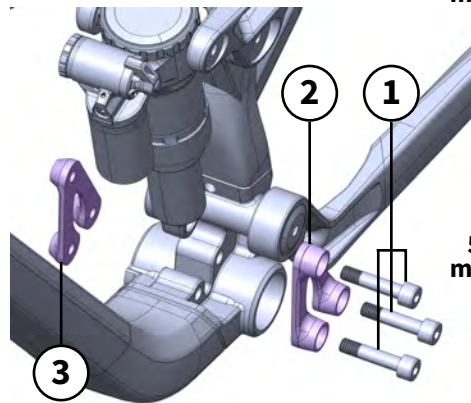

Main pivot assembly:

1. Main pivot shaft – 1 pc.
2. Main pivot bolt – 1 pc.
3. 6903 MAX LLU bearing – 3 pcs.
4. Spacer 17x23x4 – 2 pcs.

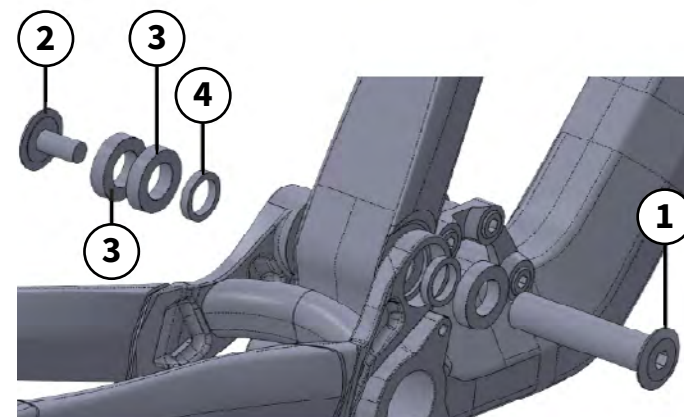

Chainstay-seat stay pivot assembly (Horst Link):

1. M8x25 DIN 7991 A2 bolt - 1 pcs.
2. Dropout pivot nut – 1 pcs.
3. Dropout pivot shaft – 1 pcs.
4. IGUS JFM-1214-05 – 2 pcs.

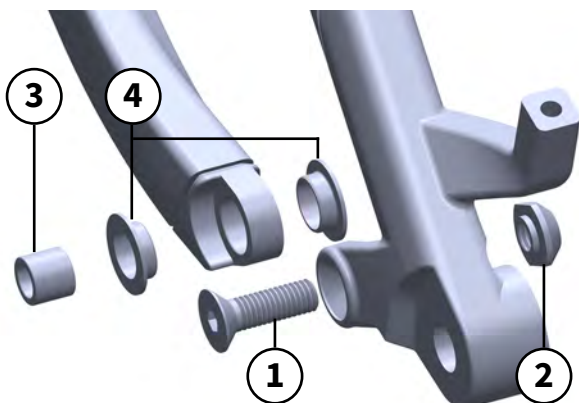

Rocker-seat stay pivot assembly:

1. Rocker - seat stay pivot shaft – 1 pcs.
2. Spacer 12x16x1 – 2 pcs.
3. F-6801 MAX LLU bearing – 2 pcs
4. Rocker - seat stay pivot bolt – 1 pcs

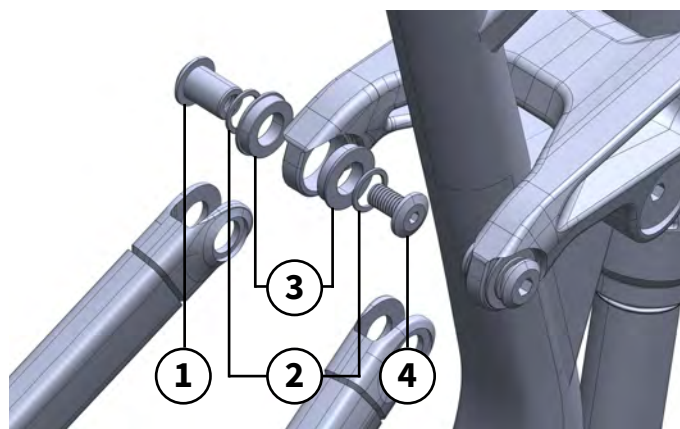

Rocker main pivot assembly:

1. Rocker main pivot bolt – 1 pcs.
2. 6902 MAX LLU bearing – 2 pcs.
3. Spacer 15x21x2.5 – 2 pcs
4. Rocker main pivot nut – 1 pcs

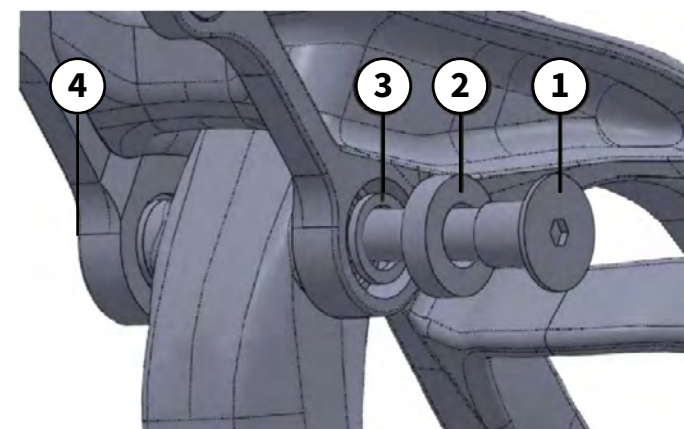



7. REAR WHEEL ASSEMBLY

To properly install the rear wheel:

- make sure that the wheel is axially aligned and that the brake disc is properly seated in the brake caliper
- put the wheel in the hooks with the chain correctly positioned on the cassette
- insert the axle 12 mm and tighten with a torque wrench to 25 Nm.

8. TIGHTENING TORQUE

Correct tightening of the bicycle fasteners, nuts, and bolts are essential. Too little force and the fastener may not hold securely. Too much force and the fastener may tear, stretch, distort or break the thread. Either way, incorrect torque can damage the component, which can cause you to lose control and fall. In case of doubt or problems found during your test ride, seek immediate advice from a professional bicycle mechanic.

See the instructions of the suppliers of the suspension fork, rear shock, and other parts that come with this frame. Do not use the bicycle until all problems have been resolved. Riding a bicycle with any defects may be dangerous to health and life. If you are not a qualified bicycle mechanic, do not make any of these adjustments yourself and seek advice from your local bicycle dealer.

The rear suspension bolts (rear shock and pivots) have been tightened at the factory to the specified torque. If you re-adjust, take particular care when re-tightening. **DO NOT** lubricate any of the pivot points. The factory uses high-quality self-lubricating Teflon.

Tightening torques (Nm) for individual points on the frame:

- Main pivot assembly: 20 Nm
- Rocker-seat stay pivot assembly: 10-12 Nm
- Chainstay-seat stay pivot assembly: 10-12 Nm
- Rocker-main pivot assembly: 20 Nm
- Upper shock bolts: 10-12 Nm
- Lower shock bolts: 10-12 Nm
- UDH compatible derailleur hanger/frame axle: 25 Nm

Thermoplastic elastomer chainstay protector for Rocbird and Rocbird Junior frames

Our custom chainstay protectors are crafted from thick thermoplastic elastomer material, offering superior impact resistance against scratches, dents, and impacts. Weight: **25g**

>>> *Check the frame accessories*

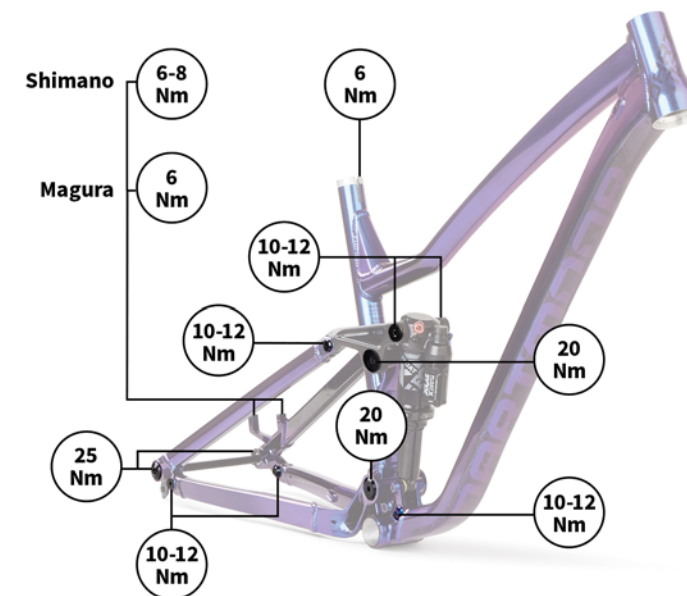

ATTENTION: Torque may vary depending on the brake manufacturer. Check the user manual for your bicycle brakes to determine the recommended torque for tightening the brake calipers.



A self-adhesive set of protective films can be used for additional protection of the downtube.

Before applying the protective film to the frame, degrease and clean its surface.

9. EXTERNAL AND INTERNAL CABLE ROUTING

- Rear derailleur cable
- Dropper post cable
- Rear brake cable (always routed outside)

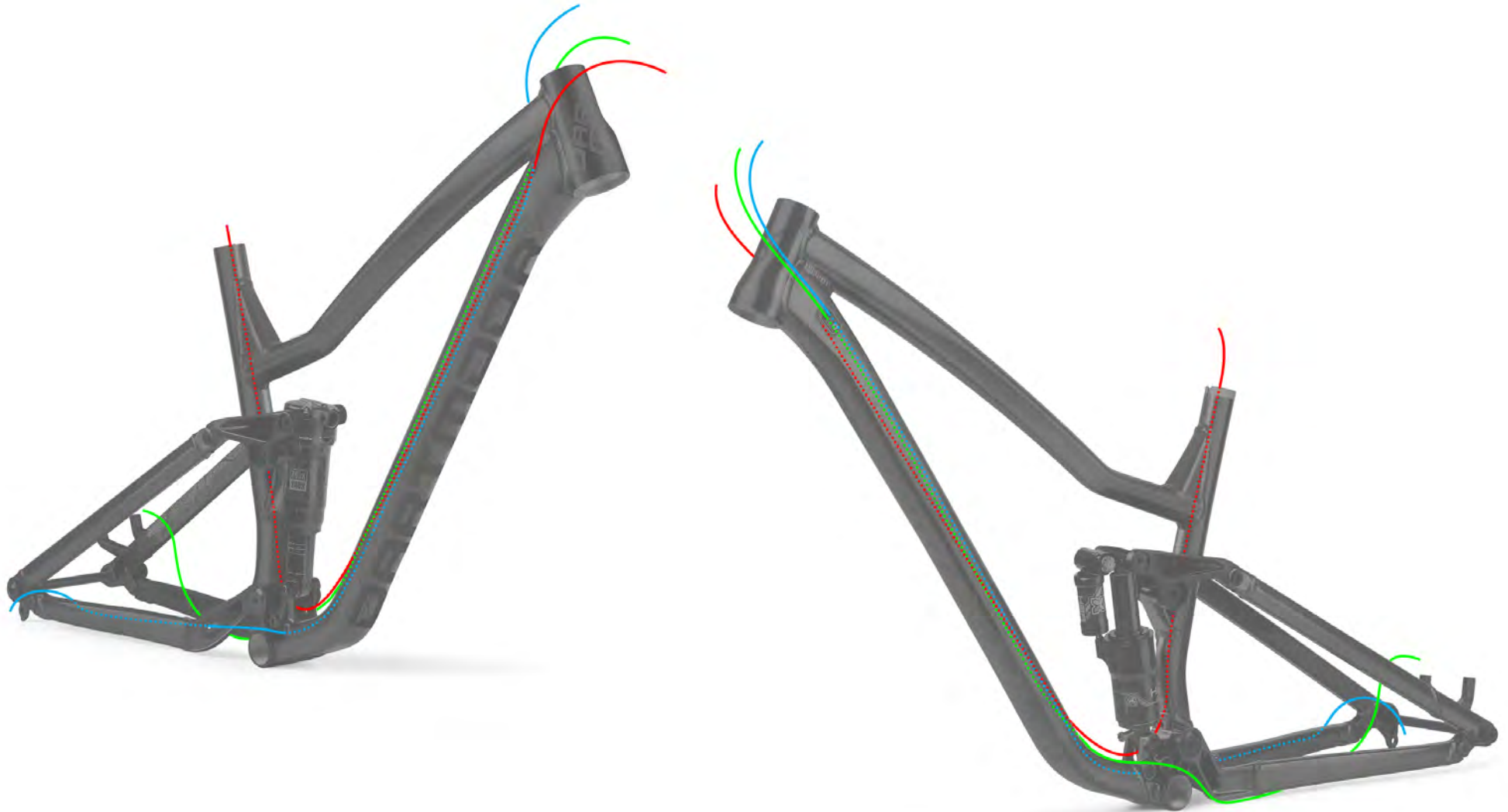

10. MAINTENANCE & SAFETY CONTROLS

Do not ride the bike if any defect is noticed.

It is recommended that the user take care of the frame of his bike, which will allow him to enjoy it for a longer period. Before each ride, the bicycle should always be inspected, which should include the following points:

- **clean the frame** - remember that high-pressure washing may damage some parts of the bike, so avoid it,
- **carefully** inspect for signs of potential failure including cracks, corrosion, dents, paint peeling, and any other signs of potential problems and misuse.
- If you find anything suspicious, contact your local bicycle dealer for a proper checkup. These are very important safety checks to prevent accidents, injuries and shorten the life of the product.

Points/things to check before each ride:

- That all frame bolts are properly tightened - see **#tightening torque**.
- Connecting the wheels to the frame and fork - is crucial for the user's safety.
- If axles are bolted, they must be properly tightened to the manufacturer's specifications.
- If there is a quick releaser, ensure that it is in the CLOSED position with the appropriate resistance level.
- The steering system includes handlebars, stems, headsets, and a fork. All elements should be properly twisted to ensure safety while riding. If the user wants to make any changes, be careful as incorrect settings can be very dangerous. It is always best to seek professional advice in this regard. Check that there is play in the rudders, the connection of the stem to the handlebars and the connection of the stem to the steerer tube, the connection between the handlebars and the stem, try to lift the handlebars up and down -there should be no movement between the two. Check that there is no addition-

al slack in the controls (stand next to the bike, tighten the front brake and push the bike back and forth. There should be no play between the frame, and the fork). If there is any play, contact your local bike shop. Do not make any adjustments yourself, unless you are sure of your abilities. Adjust the steering according to the instructions from the manufacturer of the headset. All parts of the stem should be regularly checked for damage or cracks. If a user finds anything suspicious, they should immediately contact an experienced bicycle mechanic. A damaged steering system can cause serious injury or even death.

- Connecting the bottom bracket to the frame. There should be no play between the frame and the carriage.
- The connection between cranks and the bottom bracket.
- Connecting the pedals to the cranks.

Points/things to check before each ride:

- Linkage of the derailleur to the frame - make sure that it functions properly before each ride.
- Attach the brake caliper to the frame and fork.
- The general condition of the front and rear shock (pay particular attention to any cracks, or deformation).
- Air Shock pressure (in the case of air forks). See **#suspension settings** and manufacturer's manual. Make sure the SAG does not exceed a reasonable limit. Make sure the air pressure does not exceed the limits provided by the damper / fork manufacturer.
- Clean the tubes of the rear shock and fork.
- Brake cables and their housing for kinks, rust, broken bands, or frayed ends. If any damage is noticed, the cables should be replaced immediately. Damaged cables can seriously affect braking performance.
- Be sure to follow the manufacturer's instructions for servicing the shock absorber and other parts. Instructions for the use of additional parts are provided in the box.





11. LIST OF COMPONENTS

Box includes:

- frame and set of cable inserts
- rear axle
- UDH hanger
- CS protector
- shock mounts for 205x65 mm, 185x50 mm shocks

DART
MOOR

#RIDEYOURWAY



Producent: **VELO Sp. z o.o.**
ul. Pszczyńska 305 / 44-100 Gliwice
sprzedaz@velo.com.pl