



PART NOOR

THUNDERBIRDS FULL SUSPENSION BICYCLE MANUAL

TABLE OF CONTENTS

1. Important information and warnings
2. General riding information
3. Dartmoor Thunderbirds
4. Geometry
5. Service parts / accessories
6. Suspension settings
7. Rear-wheel assemble
8. Tightening torque
9. External and internal cable routing
10. Maintenance & safety controls
11. List of components



1. INTRODUCTION – IMPORTANT INFORMATION AND WARNINGS

CAUTION: Please read this manual carefully. It contains important safety information.

WARNING: Extreme bicycle ride is a dangerous sport and requires an amazing amount of skills. By engaging in that type of activity user accepts the risk of injury or even death. Even the best bicycle will not help to drop perfectly if the user does not have sufficient skills. Also, the best protection equipment does not guarantee a hundred percent safety. Please note that in this kind of riding, a user can only trust his abilities and must accept the inherent risk. While riding a user can reach significant speeds and therefore face significant hazards and risks. Inspect a bicycle and equipment carefully and be sure that it is in perfect condition before each ride. If possible consult with bike-park personnel, expert riders, and race officials on conditions and equipment advisable. Always wear appropriate safety gear, including an approved full-face helmet, full finger gloves, body armor, bright and visible clothing that is not so loose, that it can be tangled in the bicycle or objects at the side of the road or trail, shoes that will stay on your feet and will grip the pedals (make sure that shoe laces cannot get into moving parts, and never ride barefoot or in sandals). Always use protective eyewear to protect against dirt, dust, and bugs.

WARNING: Some of the service procedures require specialist tools and good mechanical skills. Therefore, to minimize the risk of serious or even fatal accidents, maintenance and assembly work on your bike should be carried out by an authorized bicycle workshop.

WARNING: Failure to maintain, check and properly adjust the suspension system may cause suspension malfunction, in a result of which a user may lose control and fall.

WARNING: Introducing changes in the suspension adjustment can alter the handling and braking characteristics of your bicycle. It is forbidden to change the suspension adjustment unless a user is thoroughly familiar with the suspension system manufacturer's instructions and recommendations. Users should always check for changes in the handling and braking characteristics of the bicycle after the suspension has been adjusted by taking a careful test ride in a safe area.

WARNING: As with all mechanical components, the frame is subjected to wear and high stresses. Different materials and components may react to wear or stress fatigue in different ways. If the design life of a component has been exceeded, it may suddenly fail possibly causing injuries to the rider. Any form of crack, scratches, or change of color in highly stressed areas indicates that the life of the component has been reached and it should be replaced.

IMPORTANT NOTICE: This manual is not intended as a comprehensive use, service, repair, or maintenance manual. Please consult your dealer for advice and your dealer may also be able to refer you to classes, clinics, or books on bicycle use, service, repair, or maintenance.



2. GENERAL RIDING INFORMATION

Riding a bicycle can be dangerous. Keep this in mind and be cautious at all times. See and be seen. Use lights and reflective clothing in low light conditions. Wearing a helmet when riding can protect the head and save a life. Always conduct a pre-ride check (detailed information can be found further in this manual).

Never ride the bicycle if you observe any technical problems or have any doubts about the proper functioning of any elements in the bicycle.

Keep the bike clean and well maintained.

It is strongly recommended to carry a pump, spare inner tube, patch kit, and a basic tool kit.

It could be required in case of a flat tire or other common mechanical problem. If any doubts or questions ask a bicycle dealer for advice on that issue.

If the bicycle is equipped with gears and user can choose a gear combination that is the most comfortable for riding conditions. Gears will allow a rider to maintain a constant rate of pedalling. Use lower gears for going uphill and higher gears for going downhill. Ease up on your pedalling pressure when you shift gears. Ask a bicycle dealer to give more advice on that issue if needed.

Pay attention to the brakes - they can be powerful and if activated too aggressively, may cause a crash. You should spend some time to get a better feel of the brakes on a side road or empty parking lot before the first ride. Avoid riding too fast, especially downhill. It is easy to lose control of the bicycle and crash at high speeds, and also you will find it very difficult to slow down especially if the hill is steep.

If a bike has been equipped with suspension, the increased speed a rider may develop will also increase the risk of injury. For example, the front of the bike may dive on the suspension fork while hard braking. A Rider can easily lose control and fall if he is not prepared for this. Please, learn how to operate your suspension system safely. Thanks to the suspension the wheels can follow the terrain better, which improves control and comfort. This improved capacity may provide an opportunity for riding faster, but riders should be careful, not to mistake the enhanced capabilities of the bicycle for their riding skills. Improving skills takes time and practice.

It is highly recommended to use locks to protect a bicycle from theft. Even if you are planning to be away from a bicycle for just a few minutes never leave your bike unlocked while unattended.



3. DARTMOOR THUNDERBIRDS



THUNDERBIRD CF PRO



THUNDERBIRD CF EVO



THUNDERBIRD SUPERENDURO PRO



THUNDERBIRD SUPERENDURO EVO



THUNDERBIRD FR PRO



THUNDERBIRD FR EVO

FR stands for freeride, and this is what you should do with this bike. A new **Thunderbird FR frame** sits on 27.5" wheels, as they are easier to get than 26" nowadays. Coil or air - it is your choice where you want to play with it. We designed it for bikepark laps with friends that choose double black diamonds for a warm-up run. It is a progressive and stiff as hell platform ready to be wrapped, hucked, and mistreated regularly. Thunderbird FR pedals just right to keep the sweat off during beer runs while its suspension stays responsive enough to prevent cold ones from ruffling. Well, that is what our R&D team says. 180mm of rear and up to 200mm of front travel with geometry allowing to fit a 29-inch front wheel means you can easily match it with a dual crown fork and keep the eyes away from your lovely mullet. With a great price-to-build ratio, you can easily save on a bike and travel more!

For keeping the frame trouble-free, all pivot points are working on the stiff axles mounted on the sealed Max-type bearings. The progressive suspension design is perfect for both types of shocks: spring shocks and large volume air shocks. The construction reduces also the negative impact of braking on the suspension operation. If you look for some more tech talk - the head tube is ready to take the new generation of 1.8" tapered forks with 68-69mm crowns and the dropout is compatible with the SRAM Universal Derailleur Hanger (UDH).

Super-enduro. It says it all. With this aluminum beast, you are ready to huck whatever you want on the track. 170mm of travel in the back and up to 190mm in the front ensure enough room for errors and party laps. Simple Horst link design built around proven four-bar suspension is balanced for pedal efficiency and braking to shred factor. It is not a do-it-all marketing scheme

bike. We like our bikes to be as progressive and stiff as possible, ready to jump over roots rather than be glued to them. 29-inch wheels with 148x12mm Boost hubs are already an overkill to ride over rough terrain. Our Enduro Team rider uses Thunderbird Superenduro both for Downhill and EWS races during a season. Not a UCI fan? Want to be really bad? Put a double crown on it and ride like it's 2010's freeride golden age again!

For keeping the frame trouble-free, all pivot points are working on the stiff axles mounted on the sealed Max-type bearings. The progressive suspension design is perfect for both types of shocks: spring shocks and large volume air shocks. The construction reduces also the negative impact of braking on the suspension operation. If you look for some more tech talk - the head tube is ready to take the new generation of 1.8" tapered forks with 68-69mm crowns and the dropout is compatible with the SRAM Universal Derailleur Hanger (UDH).

Mountain biking is all about your limits. The more difficult trails you ride the bigger fun you may have if shred it with a well-designed frame!

Thunderbird CF is an all-new **carbon enduro frame**, dedicated to the difficult terrain and riding conditions. With perfect lateral stiffness, it is a great 29er enduro machine with aggressive geometry and 160mm of progressive frame travel. Thunderbird CF will work great with the modern heavy-duty forks with 160-170mm travel. Despite the big wheels, the new Thunderbird CF has the Dartmoor DNA and it will not let you down on big jumps, drops, or even in bike parks. For keeping the frame trouble-free, all pivot points are working on the stiff axles mounted on the sealed Max-type bearings.

The progressive suspension design of the Thunderbird CF is perfect for both types of shocks: spring shocks and large volume air shocks. The construction reduces also the negative impact of braking on the suspension operation. The front triangle and seat stays are made of high-quality carbon fiber with increased wall thickness for better stiffness. The massive rocker is made of one piece of forged aluminum. To ensure the proper strength and durability the whole chainstay and the inserts in the points that are the most exposed to overload in carbon material are made of aluminum as well.

Before we decided to launch the Thunderbird CF frame for mass production, it not only passed a series of tests on a load machine, where the overloads were much greater than required by the standards but it was also strictly tested on the toughest trails of many European enduro races by our team rider Marcin Motyka - a legend of the Polish bicycle scene. Another testing period included uncompromised shredding in the Austrian, Czech and Polish bike parks, where our R&D Jan Kiliński was checking the strength of the frame on the high drops and long jumps.

Thunderbird CF frame is equipped with SRAM Universal Derailleur Hanger (UDH).

The Thunderbird CF is available either without a shock or with the high-end Fox X2 Factory air shock with high-speed/low-speed compression and high-speed/low-speed rebound adjustments, coated with a Genuine Kashima coat.



BIKES & FRAMES RIDING STYLE CHART

	Trail	Enduro	Freeride	Downhill
Thunderbird CF PRO		■		
Thunderbird CF EVO		■		
Thunderbird Superenduro PRO		■	■	■
Thunderbird Superenduro EVO		■	■	■
Thunderbird FR PRO			■	
Thunderbird FR EVO			■	

ENDURO

Enduro bikes were created for long mountain trips in difficult terrain, riding in the mountains, often unpaved routes. These bikes are more versatile and also allow a rider to ride uphill, although it is not the most pleasant. The travel of shock absorption is smaller than that of downhill bikes. The most common are full-suspension bikes with 160mm of travel, but there are also hardtails. They have a fairly short stiff frame, an adjustable seat post, and hydraulic brakes with large discs. Sometimes there is a front derailleur. Some models even allow you to quickly change the geometry of the frame, i.e. adapt the bike to the climb or descent. Weight approx. 12-16 kg.

In enduro, the ability to efficiently overcome not only winding paths, trails full of unevenness, sharp descents, and demanding climbs will be useful. It is up to the rider which route he will take because he has full freedom in this matter. There are no inaccessible places for enduro bikes, and the more diverse the better. You can go crazy and bounce a bit off the ground. It is not the results or the quick time that counts, only having fun. This is the essence of a real enduro. A bicycle should be free, reliable, and its user should be able to use its full potential. In enduro, a rider chooses his path.

FREERIDE

Freeride bikes are downhill bikes tailored to the needs of ordinary people. Minimum stroke of the shock absorber 170 mm, solid frame, wide handlebars. All this is within the limits that can be mastered by intermediate riders. When driving fast, wide tires and sensitive hydraulic brakes are essential. The high position of the handlebars in relation to the saddle and the position of the rider shifted backward ensure comfort when riding downhill. It is also possible to overcome flat sections. The weight of around 18 kg makes the climb very difficult, which is why freeriders use the lifts most often. It is definitely a bike for fans of extreme experiences.



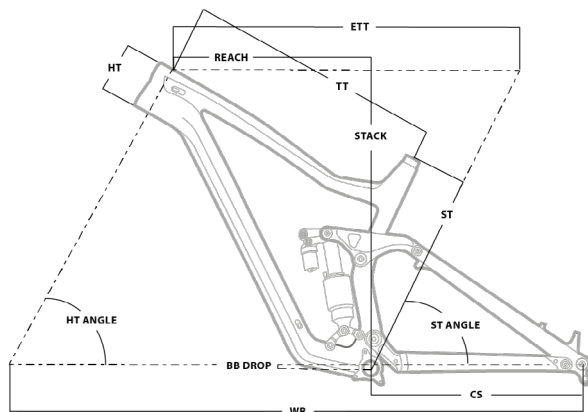

THUNDERBIRD CF PRO

>>> *Check*



THUNDERBIRD CF EVO

>>> *Check*

- Reach: horizontal distance from BB center to HT center
- Stack: vertical distance from BB center to HT center
- ST: seat tube length (BB center to ST top)
- TT: top tube length (actual)
- ETT: top tube length (effective)
- CS: chain stay length
- HT: head tube length
- HT angle: head tube angle
- EST angle: seat tube angle (effective)
- BB drop: bottom bracket height (BB center to WB)
- WB: wheel base

Size	Medium	Large
Reach	455	480
Stack	633	633
Seat tube	437	452
Eff top tube	613	638
Chainstay	435	435
Head tube	110	110
HT angle	64	64
ST angle	76	76
BB drop	27	27
Wheel base	1237	1262
Standover	760	760

Size	Medium	Large
Reach	455	480
Stack	633	633
Seat tube	437	452
Eff top tube	613	638
Chainstay	435	435
Head tube	110	110
HT angle	64	64
ST angle	76	76
BB drop	27	27
Wheel base	1237	1262
Standover	760	760

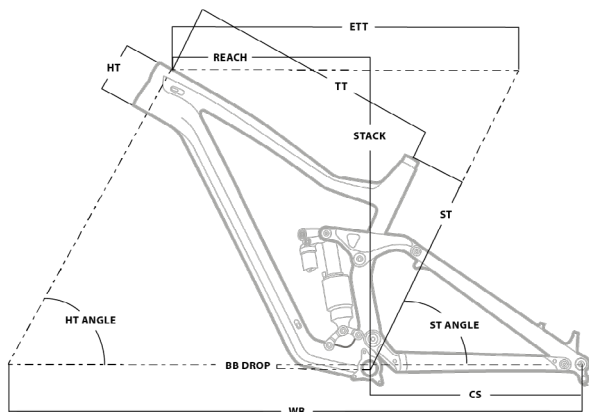

THUNDERBIRD SUPERENDURO PRO

>>> *Check*



THUNDERBIRD SUPERENDURO EVO

>>> *Check*

- Reach: horizontal distance from BB center to HT center
- Stack: vertical distance from BB center to HT center
- ST: seat tube length (BB center to ST top)
- TT: top tube length (actual)
- ETT: top tube length (effective)
- CS: chain stay length
- HT: head tube length
- HT angle: head tube angle
- EST angle: seat tube angle (effective)
- BB drop: bottom bracket height (BB center to WB)
- WB: wheel base

Size	Medium	Large	XLarge
Reach	435	460	485
Stack	640	640	640
Seat tube	430	450	470
Eff top tube	590	615	640
Chainstay	435	435	435
Head tube	110	110	110
HT angle	64	64	64
ST angle	76	76	76
BB drop	25	25	25
Wheel base	1219	1244	1269
Standover	806	806	806

Size	Medium	Large	XLarge
Reach	435	460	485
Stack	640	640	640
Seat tube	430	450	470
Eff top tube	590	615	640
Chainstay	435	435	435
Head tube	110	110	110
HT angle	64	64	64
ST angle	76	76	76
BB drop	25	25	25
Wheel base	1219	1244	1269
Standover	806	806	806

4. GEOMETRY

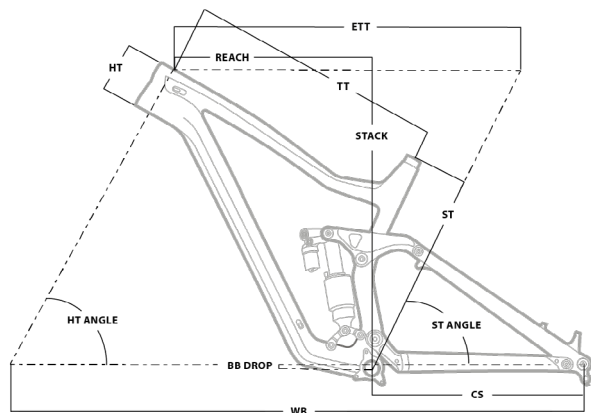

Reach: horizontal distance from BB center to HT center
 Stack: vertical distance from BB center to HT center
 ST: seat tube length (BB center to ST top)
 TT: top tube length (actual)
 ETT: top tube length (effective)
 CS: chain stay length
 HT: head tube length
 HT angle: head tube angle
 EST angle: seat tube angle (effective)
 BB drop: bottom bracket height (BB center to WB)
 WB: wheel base



>>> Check

Size	Medium	Large
Reach	445	470
Stack	619	619
Seat tube	430	450
Eff top tube	540	565
Chainstay	430	430
Head tube	110	110
HT angle	65	65
ST angle	81	81
BB drop	12	12
Wheel base	1206	1231
Standover	795	795



>>> Check

Size	Medium	Large
Reach	445	470
Stack	619	619
Seat tube	430	450
Eff top tube	540	565
Chainstay	430	430
Head tube	110	110
HT angle	65	65
ST angle	81	81
BB drop	12	12
Wheel base	1206	1231
Standover	795	795

SELECTION OF THE APPROPRIATE SIZE OF THE FRAME TO THE USER'S HEIGHT:

THUNDERBIRDS

CF PRO

size [cm] M L

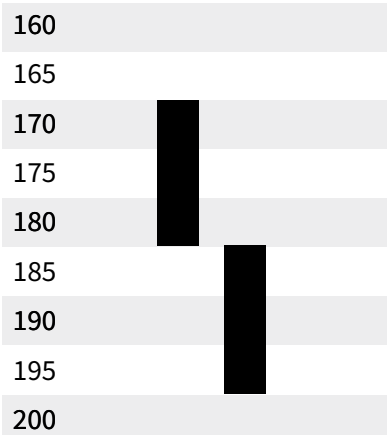

PDF >>> Open the document

SUPERENDURO PRO

size [cm] S M L

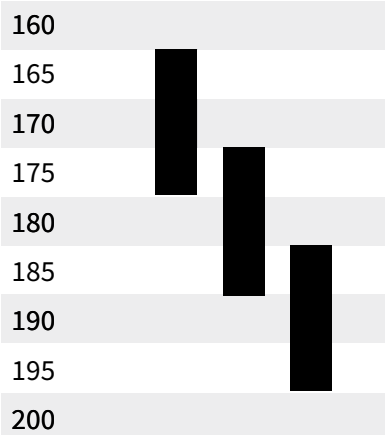

PDF >>> Open the document

FR PRO

size [cm] M L

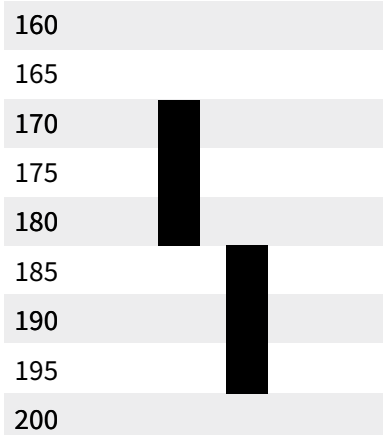

PDF >>> Open the document

CF EVO

size [cm] M L

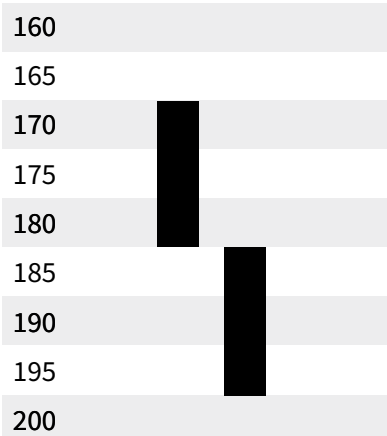

PDF >>> Open the document

SUPERENDURO EVO

size [cm] S M L

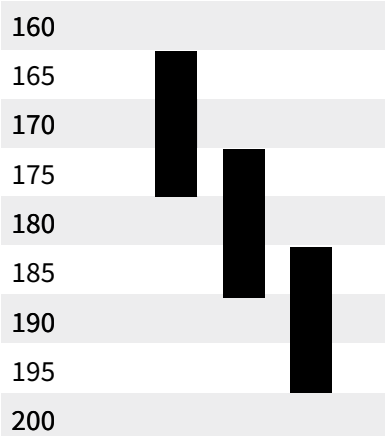

PDF >>> Open the document

FR EVO

size [cm] M L

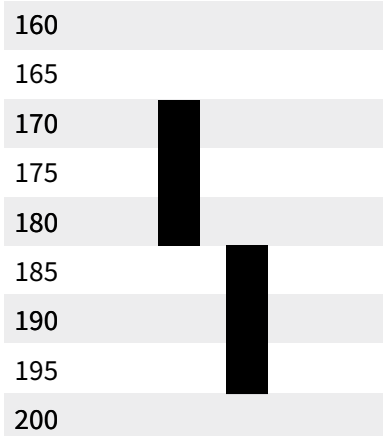

PDF >>> Open the document



5. SERVICE PARTS

We know how important it is for the user to have a working piece of equipment, especially when enduro riding can be this unpredictable sport. In this regard, we offer a list of dedicated spare parts and service parts to help properly service your Dartmoor-Bikes equipment.

Chainstay for Thunderbird CF and Suprenduro frame (aluminum), matt black/space blue



Rocker for Thunderbird CF, Suprenduro and FR (aluminum)



Seat stay bolts and main axle bolt for Thunderbird CF



Thunderbirds derailleur hanger - compatible with SRAM UDH



UDH compatible derailleur hanger/frame axle assembly.

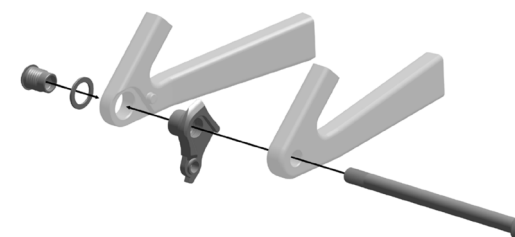

Frame axle M12xP1.0 for the Boost hub spacing 148x12mm is dedicated to use with SRAM UDH compatible gear hanger.



6. SUSPENSION SETTINGS

Tutorial video showing how to set up the suspension on a full-suspension bike.

YT >>> *Watch the video*

INITIAL SAG

Suspension settings are a matter of personal preference. Some riders prefer a soft setup, others a hard setup. Depending on the riding style, skills, and conditions on the route. The suspension on a trail/ enduro bike works fine with approximately 20% -30% initial sag. For the front shock, the value of 20-25% should be assumed, while for the rear shock the initial deflection should be about 25-30% of the total stroke. Before starting work, set the return damping to the fully open position.

To measure the SAG, follow the instructions/indications below:

- Move the O-ring on the stanchion so it touches the fork seal, the same for the rear shock
- Stand on the pedals with your full body weight with full equipment: protective armor, helmet, neck protector, water bottle or water bag, etc. It is important that the equipment and clothing reflect the real riding conditions to give the most accurate results. While standing on the bike, bend the suspension several times, then push the O-ring against the shock seals again. It is best to have someone to help, but you can deal with it yourself, for example by leaning against the wall of the building.
- Get off the bike carefully and measure the SAG with a ruler or tape measure printed on the stanchion, or ask someone to read the value on the scale when standing on the bike in a neutral po-

sition (slightly bent knees and hands in elbows). Inflate or deflate the damper until the desired deflection of the shock is achieved.

In the case of an ungraduated rear shock, to determine the percentage of initial deflection, its total deflection must first be measured, because it is shorter than those given in the catalog for the total travel of the rear swingarm. To do this, reduce the pressure in the air chamber so that you can bend the shock to its extreme position, then inflate it and measure the distance between the O-ring and the seal. For example, a bicycle with 160mm travel has a rear shock with 70.87mm deflection, assuming a SAG of 30%, its value measured on the shock absorber piston with correctly set pressure should be 21.26mm ($70.87 \times 0.3 = 21.26\text{mm}$).

REBOUND – return damping (rebound speed)

In the damper return damping setting, the so-called „curb test” works best. To proceed with the adjustment, follow the instructions/indications below:

- Unscrew the Rebound valve to the extreme position, depending on the manufacturer on the casing towards the „bunny” symbol, „Fast” or minus sign. There is no return damping in this position.
- Find a less traveled road in your area with a medium size curb.
- While sitting in the saddle, without using the brakes, slowly descend from the saddle. The damper piston retracts first, then returns to its original position and begins to oscillate until it stops.

- To counteract the “rocking” phenomenon, turn Rebound two clicks towards the “turtle” symbol (+; “slow”) and repeat the test by rolling off the curb. By adjusting in this way, you should observe the moment when the damper stops oscillating after a rebound.
- The resulting setting is the initial setting from which you should start. Further adjustments for two clicks backward or forwards can be made on the trail depending on riding conditions and preferences.
- Remember that, as with the SAG, the return suppression is determined by the weight of the user and all equipment. The greater the weight of the bike user, the greater the damping will be needed to absorb the rebound energy.

It is best to set the front shock return damping as follows:

- Start by unscrewing the damper to the extreme position as it was in the case of the damper. Stand next to the bicycle, depress the shock as far as possible, and release it vigorously. Observe that the front wheel is clear of the ground. Increase the damping by two clicks by using the adjuster on the bottom of the right shock leg, turning towards the „turtle” symbol („+”; „slow”).
- Repeat this process until the wheel stops springing off the ground. The basic setting obtained in this way can be corrected on the trail depending on the driving conditions and individual preferences.
- Finally, get on the bike and on a straight road, vigorously bending the suspension, check that the front and rear work evenly. By pressing the suspension in this way, bend it in the range of 80-90%, if it is difficult, it may turn out that the shock or damper needs to be adjusted in terms of the air chamber capacity. To do this, contact an experienced service provider who will adjust the size of the chamber with the help of tokens.

COMPRESSION – speed of compression (deflection)

Most air shocks have a compression speed damping adjustment implemented by a single knob. It enables smooth or gradual regulation until the shock is blocked. This adjustment is most often used while driving, adapting the shock to the type of route. The fully open position is most often used when descending on uneven terrain when we want the best traction. Slowing down the compression speed to about half of the range is used in normal riding on flat sections and in the case of riding on flow routes so that the suspension does not absorb the user's speed while riding on moguls. This setting is the most used and the most universal, also for people

who like to jump on a bike. The shock absorbs energy when hitting a punch, so some riders prefer to increase compression damping. The extreme setting is the least used, most often when climbing steep climbs.

More advanced designs of the shock, mount a damper with two regulators, fast and slow compression. Slow compression damping acts on the first half of the shock travel, mainly when braking, negotiating steep descents, rides, or moguls. Increasing it improves the efficiency of pedaling, prevents „swinging” and reduces the collapse of the suspension when overcoming the above-mentioned elements. Similar to the case when you have only

one compression knob. Therefore, the adjustment is made in the same way.

High-speed compression damping affects the second half of the stroke of the shock from the middle of the deflection to the moment of compression. Typically, less experienced riders do not use this adjustment and it remains in the open position. Users who like to ride more aggressively, forcing the suspension to work quickly, after hitting a large obstacle will feel that the suspension dives too quickly to the end of the stroke, they can counteract this phenomenon by increasing the damping of quick compression.



REAR SUSPENSION ASSEMBLY

Main pivot assembly:

1. Main pivot shaft – 1 pc.
2. Main pivot bolt – 1 pc.
3. 6903 MAX LLU bearing – 3 pcs.
4. Spacer 17x23x4 – 2 pcs.

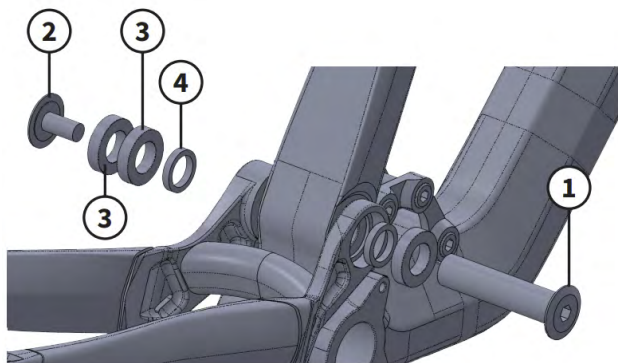

Rocker-seat stay pivot assembly:

1. Rocker-seat stay pivot shaft - 2 pcs.
2. Spacer 12x16x1 – 2 pcs.
3. F-6801 MAX LLU bearing – 4 pcs.
4. Rocker-seat stay pivot bolt – 2 pcs.

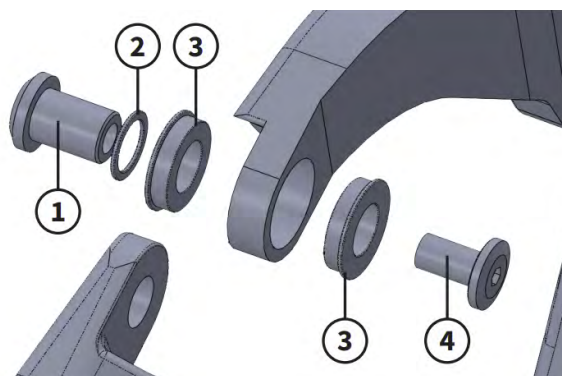

Rocker main pivot assembly:

1. Rocker main pivot bolt – 2 pcs.
2. 6902 MAX LLU bearing – 2 pcs.
3. Spacer 15x21x2.5 – 2 pcs

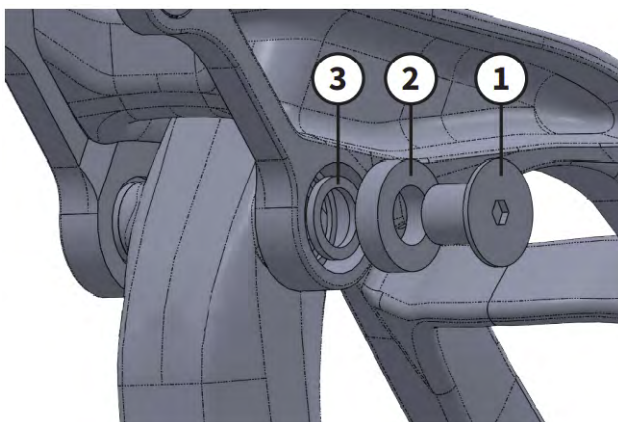

Chainstay-seat stay pivot assembly (Horst Link):

1. Chainstay-seat stay pivot shaft – 2 pcs.
2. Spacer 12x16x1 – 4 pcs.
3. F-6801 MAX LLU bearing – 4 pcs.
4. Chainstay-seat stay pivot bolt - 2 pcs.

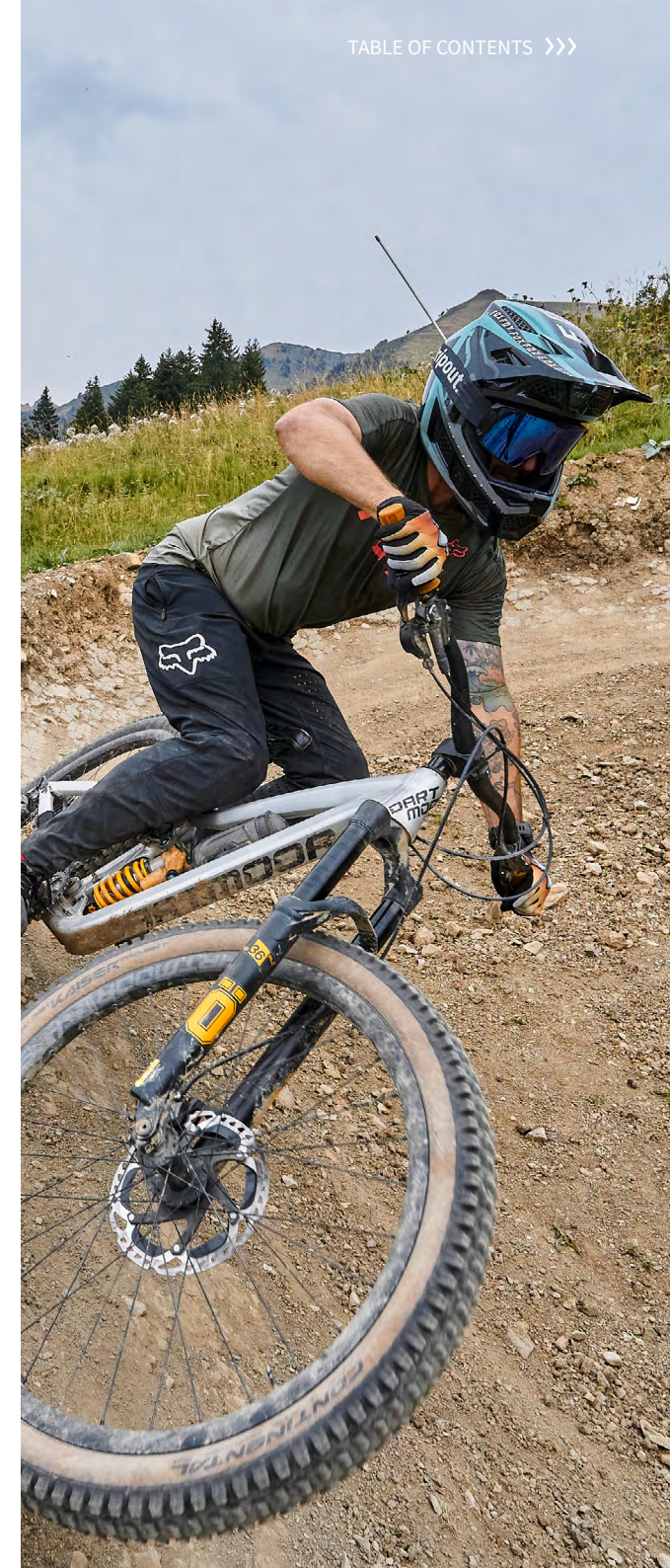
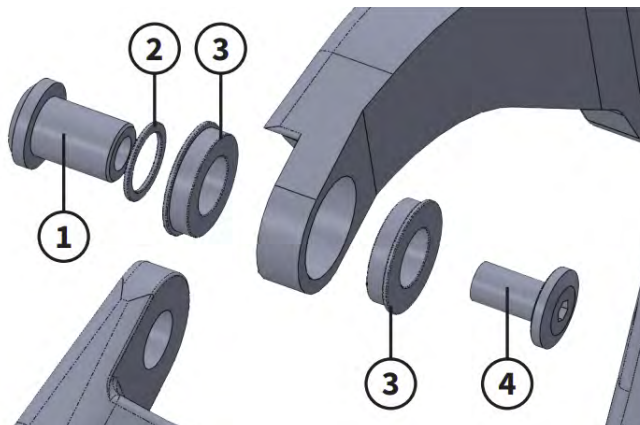



7. REAR WHEEL ASSEMBLY

To properly install the rear wheel:

- make sure that the wheel is axially aligned and that the brake disc is properly seated in the brake caliper
- put the wheel in the hooks with the chain correctly positioned on the cassette
- insert the axle 12 mm and tighten with a torque wrench to 25 Nm.

8. TIGHTENING TORQUE

Correct tightening of the bicycle fasteners, nuts, and bolts are essential. Too little force and the fastener may not hold securely. Too much force and the fastener may tear, stretch, distort or break the thread. Either way, incorrect torque can damage the component, which can cause you to lose control and fall. In case of doubt or problems found during your test ride, seek immediate advice from a professional bicycle mechanic.

See the instructions of the suppliers of the suspension fork, rear shock, and other parts that come with this frame. Do not use the bicycle until all problems have been resolved. Riding a bicycle with any defects may be dangerous to health and life. If you are not a qualified bicycle mechanic, do not make any of these adjustments yourself and seek advice from your local bicycle dealer.

ACCESSORIES:

The rocker arm neoprene tube protector should be wrapped together with the rear derailleur cable to protect the rocker arm from chain impacts.

A self-adhesive set of protective films can be used for additional protection of the downtube.

Before applying the protective film to the frame, degrease and clean its surface.

The rear suspension bolts (rear shock and pivots) have been tightened at the factory to the specified torque. If you re-adjust, take particular care when re-tightening. **DO NOT** lubricate any of the pivot points. The factory uses high-quality self-lubricating Teflon.

Tightening torques (Nm) for individual points on the frame:

- Main pivot assembly: 20 Nm
- Rocker-seat stay pivot assembly: 10-12 Nm
- Chainstay-seat stay pivot assembly: 10-12 Nm
- Rocker main pivot assembly: 15 Nm
- Upper shock bolts: 10-12 Nm
- Lower shock bolts: 10-12 Nm
- UDH compatible derailleur hanger/frame axle: 25 Nm

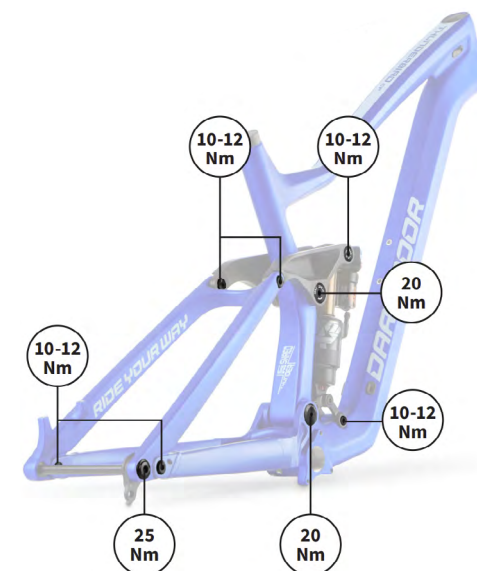

CS Protector for Thunderbird CF/AL

Thermoplastic elastomer chainstay protector for Thunderbird CF, Thunderbird Superenduro, and Thunderbird FR frames.

Weight: **48g**



DT Protector for Thunderbird CF

Thermoplastic elastomer down tube protector for Thunderbird CF frame.

Weight: **92g**



9. EXTERNAL AND INTERNAL CABLE ROUTING

- Rear derailleur cable
- Dropper post cable
- Rear brake cable (always routed outside)

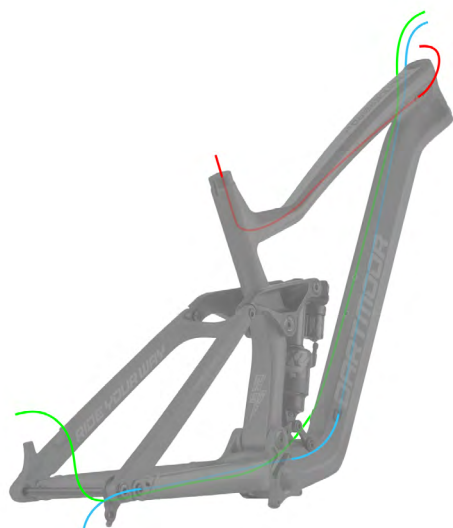
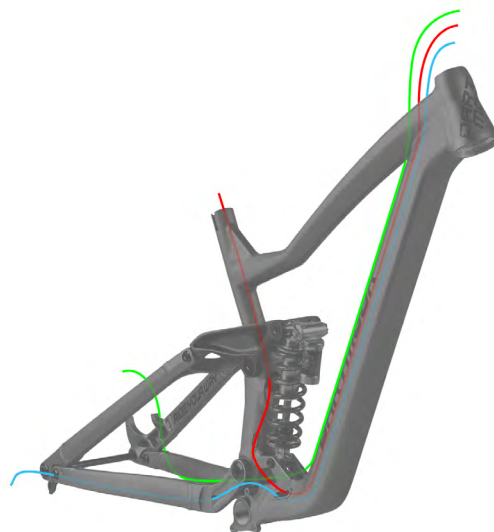
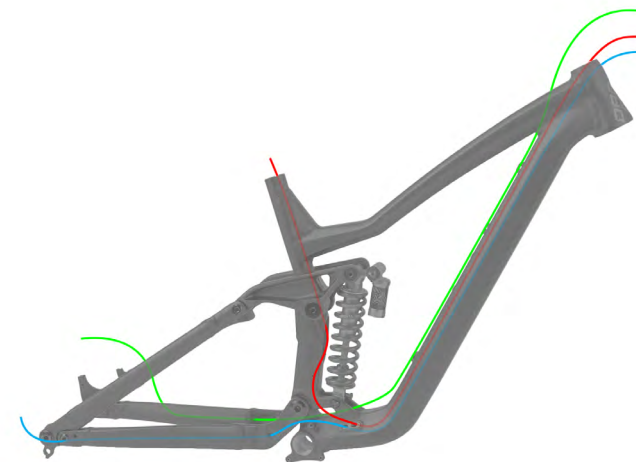
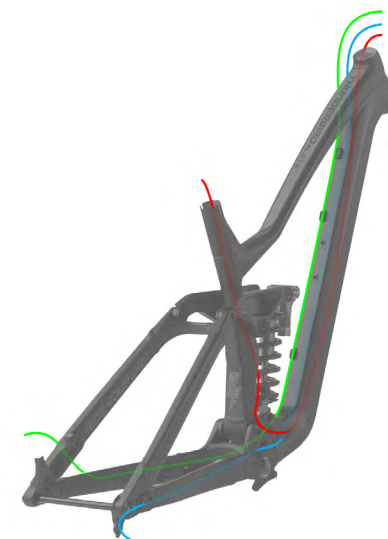
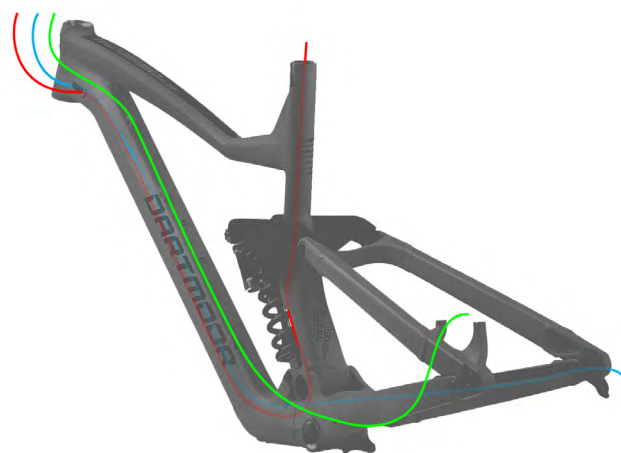
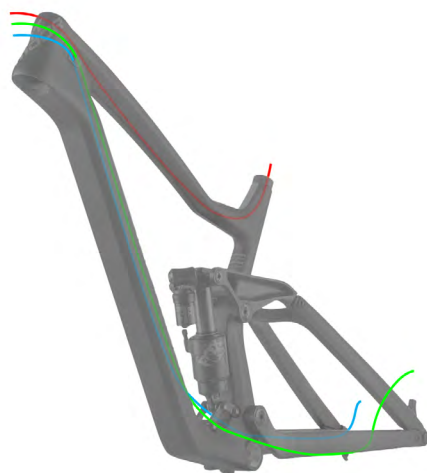
**CF****SUPERENDURO****FR**

10. MAINTENANCE & SAFETY CONTROLS

Do not ride the bike if any defect is noticed.

It is recommended that the user take care of the frame of his bike, which will allow him to enjoy it for a longer period. Before each ride, the bicycle should always be inspected, which should include the following points:

- clean the frame - remember that high-pressure washing may damage some parts of the bike, so avoid it,
- **carefully** inspect for signs of potential failure including cracks, corrosion, dents, paint peeling, and any other signs of potential problems and misuse.
- If you find anything suspicious, contact your local bicycle dealer for a proper checkup. These are very important safety checks to prevent accidents, injuries and shorten the life of the product.

Points/things to check before each ride:

- That all frame bolts are properly tightened - see **#tightening torque**.
- Connecting the wheels to the frame and fork - is crucial for the user's safety.
- If axles are bolted, they must be properly tightened to the manufacturer's specifications.
- If there is a quick releaser, ensure that it is in the CLOSED position with the appropriate resistance level.
- The steering system includes handlebars, stems, headsets, and a fork. All elements should be properly twisted to ensure safety while riding. If the user wants to make any changes, be careful as incorrect settings can be very dangerous. It is always best to seek professional advice in this regard. Check that there is play in the rudders, the connection of

the stem to the handlebars and the connection of the stem to the steerer tube, the connection between the handlebars and the stem, try to lift the handlebars up and down - there should be no movement between the two. Check that there is no additional slack in the controls (stand next to the bike, tighten the front brake and push the bike back and forth. There should be no play between the frame, and the fork). If there is any play, contact your local bike shop. Do not make any adjustments yourself, unless you are sure of your abilities. Adjust the steering according to the instructions from the manufacturer of the headset. All parts of the stem should be regularly checked for damage or cracks. If a user finds anything suspicious, they should immediately contact an experienced bicycle mechanic. A damaged steering system can cause serious injury or even death.

- Connecting the bottom bracket to the frame. There should be no play between the frame and the carriage.
- The connection between cranks and the bottom bracket.
- Connecting the pedals to the cranks.

Points/things to check before each ride:

- Linkage of the derailleur to the frame - make sure that it functions properly before each ride.
- Attach the brake caliper to the frame and fork.
- The general condition of the front and rear shock (pay particular attention to any cracks, or deformation).
- Air Shock pressure (in the case of air forks). See **#suspension settings** and manufacturer's manual. Make sure the SAG does not exceed a reasonable limit. Make sure the air pressure does not exceed the limits provided by the damper / fork manufacturer.

- Clean the tubes of the rear shock and fork.
- Brake cables and their housing for kinks, rust, broken bands, or frayed ends. If any damage is noticed, the cables should be replaced immediately. Damaged cables can seriously affect braking performance.
- Be sure to follow the manufacturer's instructions for servicing the shock absorber and other parts. Instructions for the use of additional parts are provided in the box.



11. LIST OF COMPONENTS

- frame
- axles
- set of cable inserts
- technical manual

DART
MOOR

#RIDEYOURWAY



Producent: **VELO Sp. z o.o.**
ul. Pszczyńska 305 / 44-100 Gliwice
sprzedaz@velo.com.pl