



# PART MOOR

**BLACKBIRD AND BLUEBIRD FULL SUSPENSION BICYCLE MANUAL**

# TABLE OF CONTENTS



1. Important information and warnings
2. General riding information
3. Blackbird and Bluebird
4. Geometry
5. Service parts / accessories
6. Suspension settings
7. Rear-wheel assemble
8. General Information
9. Tightening torque
10. External cable routing
11. Internal cable routing
12. Maintenance & safety controls
13. List of componens

# 1. INTRODUCTION – IMPORTANT INFORMATION AND WARNINGS

**CAUTION:** Please read this manual carefully. It contains important safety information.

**WARNING:** Extreme bicycle ride is a dangerous sport and requires an amazing amount of skills. By engaging in that type of activity user accepts the risk of injury or even death. Even the best bicycle will not help to drop perfectly if the user does not have sufficient skills. Also, the best protection equipment does not guarantee a hundred percent safety. Please note that in this kind of riding, a user can only trust his abilities and must accept the inherent risk. While riding a user can reach significant speeds and therefore face significant hazards and risks. Inspect a bicycle and equipment carefully and be sure that it is in perfect condition before each ride. If possible consult with bike-park personnel, expert riders, and race officials on conditions and equipment advisable. Always wear appropriate safety gear, including an approved full-face helmet, full finger gloves, body armor, bright and visible clothing that is not so loose, that it can be tangled in the bicycle or objects at the side of the road or trail, shoes that will stay on your feet and will grip the pedals (make sure that shoe laces cannot get into moving parts, and never ride barefoot or in sandals). Always use protective eyewear to protect against dirt, dust, and bugs.

**WARNING:** Some of the service procedures require specialist tools and good mechanical skills. Therefore, to minimize the risk of serious or even fatal accidents, maintenance and assembly work on your bike should be carried out by an authorized bicycle workshop.

**WARNING:** Failure to maintain, check and properly adjust the suspension system may cause suspension malfunction, in a result of which a user may lose control and fall.

**WARNING:** Introducing changes in the suspension adjustment can alter the handling and braking characteristics of your bicycle. It is forbidden to change the suspension adjustment unless a user is thoroughly familiar with the suspension system manufacturer's instructions and recommendations. Users should always check for changes in the handling and braking characteristics of the bicycle after the suspension has been adjusted by taking a careful test ride in a safe area.

**WARNING:** As with all mechanical components, the frame is subjected to wear and high stresses. Different materials and components may react to wear or stress fatigue in different ways. If the design life of a component has been exceeded, it may suddenly fail possibly causing injuries to the rider. Any form of crack, scratches, or change of color in highly stressed areas indicates that the life of the component has been reached and it should be replaced.

**IMPORTANT NOTICE:** This manual is not intended as a comprehensive use, service, repair, or maintenance manual. Please consult your dealer for advice and your dealer may also be able to refer you to classes, clinics, or books on bicycle use, service, repair, or maintenance.



## 2. GENERAL RIDING INFORMATION

Riding a bicycle can be dangerous. Keep this in mind and be cautious at all times. See and be seen. Use lights and reflective clothing in low light conditions. Wearing a helmet when riding can protect the head and save a life. Always conduct a pre-ride check (detailed information can be found further in this manual).

Never ride the bicycle if you observe any technical problems or have any doubts about the proper functioning of any elements in the bicycle.

Keep the bike clean and well maintained.

It is strongly recommended to carry a pump, spare inner tube, patch kit, and a basic tool kit.

It could be required in case of a flat tire or other common mechanical problem. If any doubts or questions ask a bicycle dealer for advice on that issue.

If the bicycle is equipped with gears and user can choose a gear combination that is the most comfortable for riding conditions. Gears will allow a rider to maintain a constant rate of pedaling. Use lower gears for going uphill and higher gears for going downhill. Ease up on your pedaling pressure when you shift gears. Ask a bicycle dealer to give more advice on that issue if needed.

Pay attention to the brakes - they can be powerful and if activated too aggressively, may cause a crash. You should spend some time to get a better feel of the brakes on a side road or empty parking lot before the first ride. Avoid riding too fast, especially downhill. It is easy to lose control of the bicycle and crash at high speeds, and also you will find it very difficult to slow down especially if the hill is steep.

If a bike has been equipped with suspension, the increased speed a rider may develop will also increase the risk of injury. For example, the front of the bike may dive on the suspension fork while hard braking. A Rider can easily lose control and fall if he is not prepared for this. Please, learn how to operate your suspension system safely. Thanks to the suspension the wheels can follow the terrain better, which improves control and comfort. This improved capacity may provide an opportunity for riding faster, but riders should be careful, not to mistake the enhanced capabilities of the bicycle for their riding skills. Improving skills takes time and practice.

It is highly recommended to use locks to protect a bicycle from theft. Even if you are planning to be away from a bicycle for just a few minutes never leave your bike unlocked while unattended.



### 3. BLACKBIRD AND BLUEBIRD



**BLACKBIRD**



**BLUEBIRD**

A reliable and functional solution(system) could be simple. Based on an opinion that comes from rider's feedback, Dartmoor enhances the ideas and provides new solutions which make every minute on trails full of fun and happiness. A bicycle is a simple machine with massive potential. That is why designing Blackbird frame 160mm of travel, modern geometry and tough but lightweight construction, Dartmoor chose simplicity and functionality. Without any doubt, Enduro is a sport that requires maximum versatility from a bicycle. Long climbs, descents in the most difficult conditions, jumps, and drops - these are the standard challenges that the equipment has to face. For those who seek trail bicycle which is durable as Enduro, the Dartmoor team has made Bluebird frame 130 mm of travel.

Based on its own and other riders' experience, Dartmoor has placed a rigid, single-pivot structure at the heart of the bike. That simple solution allows us to create a modern product that will meet the expectations of even the most demanding riders. The advanced swingarm cage, consisting of 12 welded parts and tubes, is very stiff, and the carefully de-

signed pivot position allows for high pedaling efficiency. The design uses an extended shock mount to keep the seat tube intact to accommodate any type of dropper post. The low position of the bottom bracket ensures

high stability on rough terrain, and the flat head tube angle (Blackbird  $65^\circ$ , Bluebird  $66^\circ$ ) ensures excellent ride control no matter how steep the trail. The rear axle is a 148 x 12 mm bolt in Boost standard.

#### Anti-squat diagram

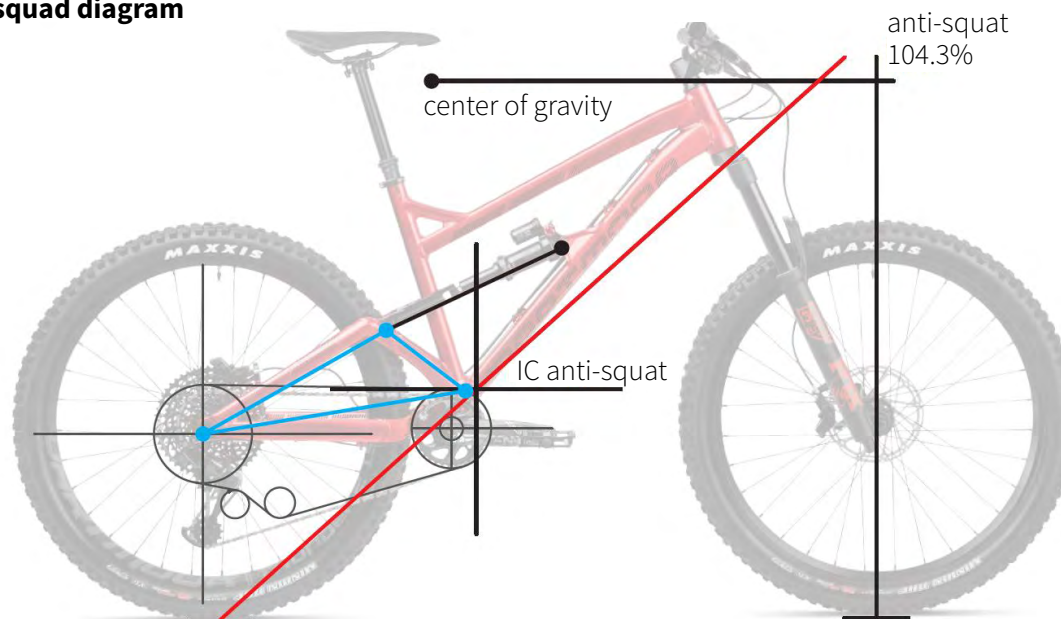

The Dartmoor frames are based on a well-designed single pivot suspension that uses the damper extension yoke for superior performance.

On the one hand, when the user is struggling with difficult climbs using low gear, he can enjoy high pedaling efficiency with anti-squand properties of around 100%. On the other hand, when it hits the toughest descents at high gear, it uses 160mm of full travel, the suspension design gives a pedal kickback of less than 2%. This results in less fatigue during descents, because the legs do not have to absorb the energy of so many hits.

The suspension kinematics of our frames are linear, the configuration is completely up to the user and his preferences, depending on how the user tunes the rear shock using the tokens. From a more progressive with a limited air chamber for those who like bigger jumps, to a more linear curve using a full stroke for those who prefer demanding trails rather than hitting huge drops. Nevertheless, the suspension is only „half the battle”. Equipped with a rigid 17mm axis of rotation, the linkage of the swingarm to the front triangle, it spins on three Max bearings (with increased ball count) with LLU full contact seals filled with high-quality Mobil synthetic grease, providing better protection against dust and water. Fewer pivot points in the designed suspension structure give less chance of catching a play in the bearings. Therefore, when buying a Dartmoor frame, the future owner receives the perfect equipment to overcome the most demanding routes.



## BIKES & FRAMES RIDING STYLE CHART:

	Downhill	Freeride	Enduro	Trail
Blackbird 27.5/29			████████████████████	
Bluebird 27.5/29			████████████████████	
Blackbird Junior			████████████████████	

### TRAIL

Trail bikes allow riders comfortable uphill on long mountain trails, combining the features of enduro and cross country. They are available in full-suspension or hardtail versions. Shock absorption at a level between 130 mm - 150 mm, will allow a rider to easily deal with unevenness and obstacles, such as steep climbs. They allow for more aggressive driving than cross country but are less dynamic. Compared to the enduro, they are a bit lighter and allow for a more pleasant ride uphill. The maneuverability of these bikes is influenced by the wide handlebars, adjustable seat post, and the weighting of the front wheel during the descent. Wheels are usually 29 inches, although trail bikes with a combination of 29 „front and 27.5” rear wheels (the so-called Mullet) are also popular, as well as with both 27.5 „wheels. The use of wide tires makes it easier to overcome obstacles in the field. Based on the emerging bike parks, a group of trail bike enthusiasts has emerged. If someone would like to go on a long trip on singletrack and not the most difficult mountain paths for pleasure, he should opt for a comfortable trail bike rather than enduro.

### ENDURO

Enduro bikes were created for long mountain trips in difficult terrain, riding in the mountains, often unpaved routes. These bikes are more versatile and also allow a rider to ride uphill, although it is not the most pleasant. The travel of shock absorption is smaller than that of downhill bikes. The most common are full-suspension bikes with 160mm of travel, but there are also hardtails. They have a fairly short stiff frame, an adjustable seat post, and hydraulic brakes with large discs. Sometimes there is a front derailleur. Some models even allow you to quickly change the geometry of the frame, i.e. adapt the bike to the climb or descent. Weight approx. 12-16 kg.

In enduro, the ability to efficiently overcome not only winding paths, trails full of unevenness, sharp descents, and demanding climbs will be useful. It is up to the rider which route he will take because he has full freedom in this matter. There are no inaccessible places for enduro bikes, and the more diverse the better. You can go crazy and bounce a bit off the ground. It is not the results or the quick time that counts, only having fun. This is the essence of a real enduro. A bicycle should be free, reliable, and its user should be able to use its full potential. In enduro, a rider chooses his path.

### FREERIDE

Freeride bikes are downhill bikes tailored to the needs of ordinary people. Minimum stroke of the shock absorber 170 mm, solid frame, wide handlebars. All this is within the limits that can be mastered by intermediate riders. When driving fast, wide tires and sensitive hydraulic brakes are essential. The high position of the handlebars in relation to the saddle and the position of the rider shifted backward ensure comfort when riding downhill. It is also possible to overcome flat sections. The weight of around 18 kg makes the climb very difficult, which is why freeriders use the lifts most often. It is definitely a bike for fans of extreme experiences.

### DOWNHILL

Downhill bikes are bikes designed for descents(downhills) at high speed, in difficult and steep terrain. The rider reaches speeds of up to 80 km / h on a rocky and bumpy route. It also happens that these bikes bounce into the air by avoiding obstacles. Such overload forces the use of bicycles with a compact and stiff structure. The sturdy frame has a low center of gravity, and the wide handlebars with a short stem increase the maneuverability of the bike. Strong and resistant tires are required, full suspension with long travel, usually 180 mm to 220 mm, and hydraulic brakes with large 203 mm discs. DH bicycles weigh approximately 15-20 kg. Their construction practically excludes going uphill, because the damper absorbs almost all the energy put into pedaling. Even navigating on flat terrain can be difficult, which is why the ski slopes are usually located near the lifts.

# 4. GEOMETRY



**BLACKBIRD EVO 29" 2022**

>>> Check



**BLACKBIRD EVO 27.5" 2022**

>>> Check



**BLACKBIRD INTRO 29" 2022**

>>> Check



**BLACKBIRD INTRO 27.5" 2022**

>>> Check

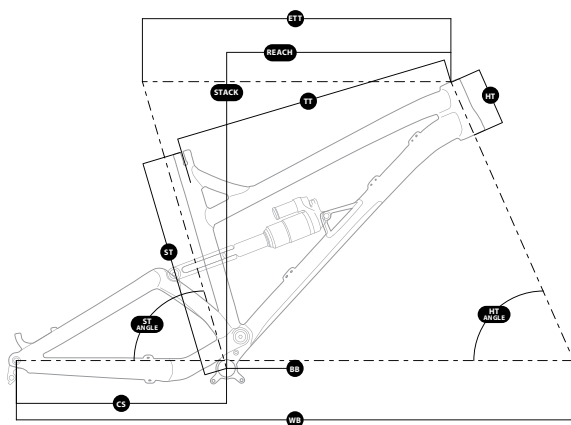

- Reach: horizontal distance from BB center to HT center
- Stack: vertical distance from BB center to HT center
- ST: seat tube length (BB center to ST top)
- TT: top tube length (actual)
- ETT: top tube length (effective)
- CS: chain stay length
- HT: head tube length
- HT angle: head tube angle
- EST angle: seat tube angle (effective)
- BB drop: bottom bracket height (BB center to WB)
- WB: wheel base

Size	Medium	Large	XLarge
Reach	450	480	505
Stack	635	635	635
Seat tube	450	480	490
Eff top tube	594	624	649
Chainstay	448	448	448
Head tube	120	120	120
HT angle	65	65	65
ST angle	77	77	77
BB drop	30	30	30
Wheel base	1235	1265	1290
Standover	825	825	825

Size	Small	Medium	Large	XLarge
Reach	400	435	460	485
Stack	606	606	606	606
Seat tube	405	430	455	480
Eff top tube	552	587	612	637
Chainstay	429	429	429	429
Head tube	120	120	120	120
HT angle	65	65	65	65
ST angle	76	76	76	76
BB drop	14	14	14	14
Wheel base	1151	1186	1211	1236
Standover	790	790	790	790





**BLUEBIRD PRO 29" 2022**

>>> Check



**BLUEBIRD PRO 27.5" 2022**

>>> Check



**BLUEBIRD EVO 29" 2022**

>>> Check



**BLUEBIRD EVO 27.5" 2022**

>>> Check

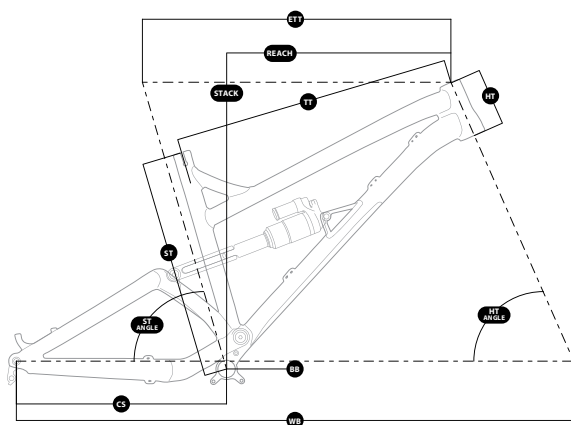

Reach: horizontal distance from BB center to HT center  
 Stack: vertical distance from BB center to HT center  
 ST: seat tube length (BB center to ST top)  
 TT: top tube length (actual)  
 ETT: top tube length (effective)  
 CS: chain stay length  
 HT: head tube length  
 HT angle: head tube angle  
 ST angle: seat tube angle (effective)  
 BB drop: bottom bracket height (BB center to WB)  
 WB: wheel base

Size	Medium	Large	XLarge
Reach	435	460	485
Stack	618	618	618
Seat tube	450	460	480
Eff top tube	587	612	637
Chainstay	439	439	439
Head tube	110	110	110
HT angle	66	66	66
ST angle	76	76	76
BB drop	35	35	35
Wheel base	1178	1203	1228
Standover	820	820	820

Size	Small	Medium	Large
Reach	415	435	465
Stack	597	597	597
Seat tube	400	430	460
Eff top tube	590	610	640
Chainstay	431	431	431
Head tube	110	110	110
HT angle	66	66	66
ST angle	74	74	74
BB drop	23	23	23
Wheel base	1136	1156	1166
Standover	785	785	785

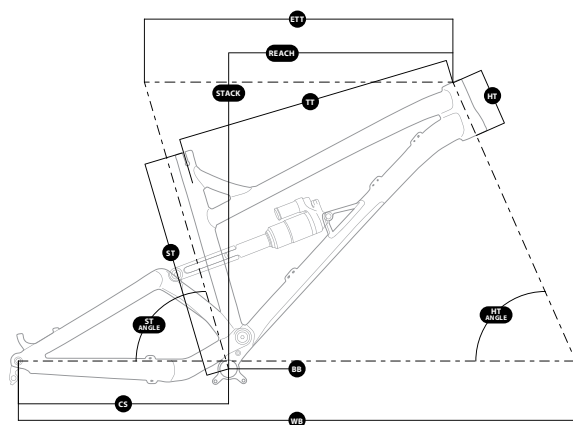
**BLUEBIRD** INTRO MULLET 2022>>> *Check*

Size	Small	Medium	Large
Reach	407	428	458
Stack	603	603	603
Seat tube	400	430	460
Eff top tube	590	610	640
Chainstay	431	431	431
Head tube	110	110	110
HT angle	65.5	65.5	65.5
ST angle	74	74	74
BB drop	17/31	17/31	17/31
Wheel base	1140	1160	1190
Standover	790	790	790

**BLACKBIRD** JUNIOR SPACE BLUE 2022>>> *Check*

Size	One size
Reach	365
Stack	558
Seat tube	360
Eff top tube	502
Chainstay	425
Head tube	100
HT angle	66
ST angle	73
BB drop	14
Wheel base	1075
Standover	750

Reach: horizontal distance from BB center to HT center  
 Stack: vertical distance from BB center to HT center  
 ST: seat tube length (BB center to ST top)  
 TT: top tube length (actual)  
 ETT: top tube length (effective)  
 CS: chain stay length  
 HT: head tube length  
 HT angle: head tube angle  
 EST angle: seat tube angle (effective)  
 BB drop: bottom bracket height (BB center to WB)  
 WB: wheel base

## SELECTION OF THE APPROPRIATE SIZE OF THE FRAME TO THE USER'S HEIGHT:

Size fitting chart 2021:

### BLACKBIRD

#### EVO 29

size [cm] M L XL

160			
165			
170	■		
175			
180	■	■	
185			
190		■	■
195			
200			■

[PDF >>> Open the document](#)

#### INTRO 29

size [cm] M L XL

160			
165			
170	■		
175			
180	■	■	
185			
190		■	■
195			
200			■

[PDF >>> Open the document](#)

### BLUEBIRD

#### PRO 29

size [cm] M L XL

160			
165			
170	■		
175			
180	■	■	
185			
190		■	■
195			
200			■

[PDF >>> Open the document](#)

#### EVO 29

size [cm] M L XL

160			
165			
170	■		
175			
180	■	■	
185			
190		■	■
195			
200			■

[PDF >>> Open the document](#)

#### INTRO MULLET

size [cm] S M L

160	■		
165			
170	■	■	
175			
180		■	■
185			
190			■
195			
200			

[PDF >>> Open the document](#)

#### EVO 27.5

size [cm] S M L XL

160	■			
165				
170	■	■		
175				
180		■	■	
185				
190			■	■
195				
200				■

[PDF >>> Open the document](#)

#### INTRO 27.5

size [cm] S M L XL

160	■			
165				
170	■	■		
175				
180		■	■	
185				
190			■	■
195				
200				■

[PDF >>> Open the document](#)

#### PRO 27.5

size [cm] S M L

160	■		
165			
170	■	■	
175			
180		■	■
185			
190		■	
195			
200			

[PDF >>> Open the document](#)

#### EVO 27.5

size [cm] S M L

160	■		
165			
170	■	■	
175			
180		■	■
185			
190			■
195			
200			

[PDF >>> Open the document](#)

## 5. SERVICE PARTS / ACCESSORIES

A complete set of bearings, axles, bolts, nuts, and spacers are available for Blackbirds and Bluebirds.



The main axle assemble:

1. Main pivot bolt – 1 pc.
2. Main pivot screw – 1 pc.
3. Bearing 6903 MAX LLU – 3 pcs.
4. Spacer 17x24x3 – 2 pcs.

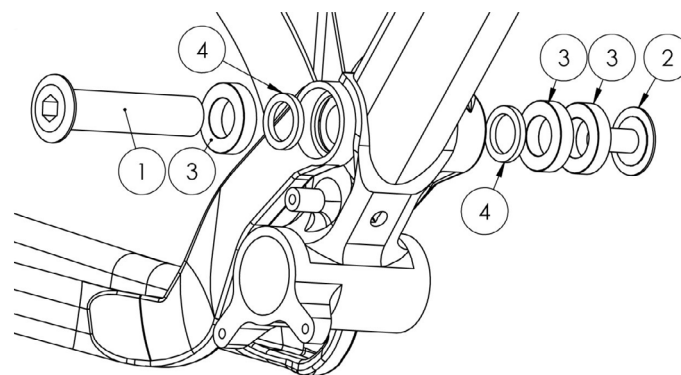

Rocker arm yoke assemble:

1. Bolt assemble yoke rocker arm - 2no. bolt for mounting yoke bar yoke / Control arm yoke mounting bolt
2. Spacer 12x16x2 – 4 pcs.
3. Bearing 6801 MAX LLU – 2 pcs.

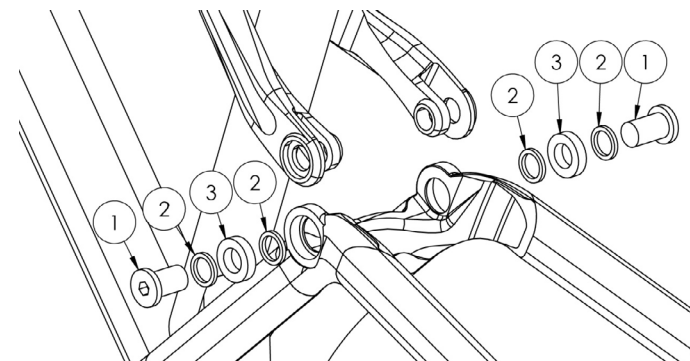

Shock absorber assemble

1. Rear shock yoke bolt – 1 pc.
2. Rocker arm pivot – 1 pc.
3. Shock absorber pin - 1 pc.
4. Screw fixing the shock absorber to the frame - 2 pcs.

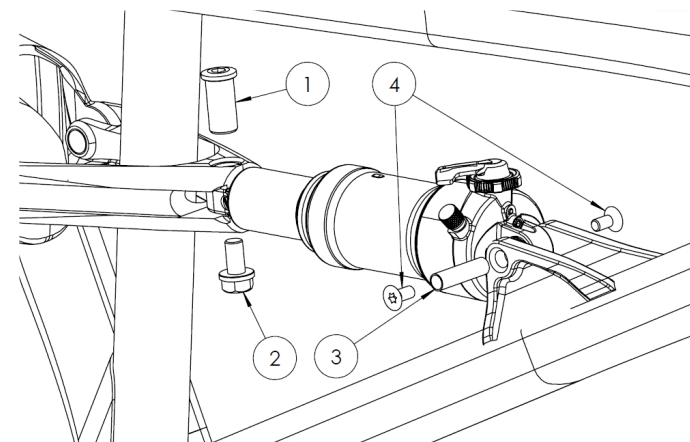

## Shock absorber and rocker arm joint (junction)



## Deraillieur hanger:

1. Deraillieur hanger (1)
2. deraillieur hanger nut (2)

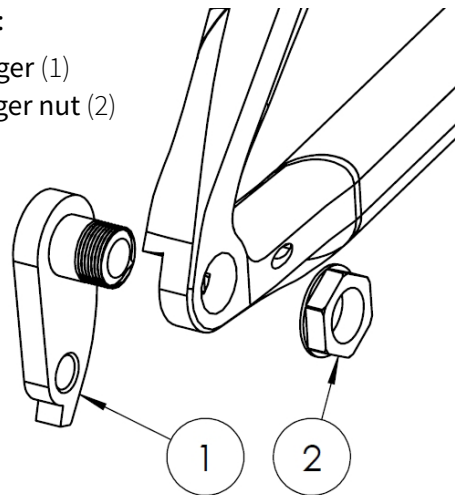

Currently, the most commonly used hub size standard is Boost (technology) - 148x12 mm for the rear hub, and 110x15 mm for the front hub. It is a relatively new solution in which the wider track increases the stiffness of the wheel, maneuverability, and dynamics of the bicycle.

Other, slightly older standards for hub sizes are 142x12 mm and 135x10mm for the rear hub, as well as 100x15 mm, 110x20 mm, and 100x9 mm for the front hub.

**Blackbird 29** - hub size 148x12mm

**Blackbird 27.5** - hub size 148x12mm (since 2021, before 142x12 mm)

**Bluebird 29** - hub size 148x12mm

**Bluebird 27.5** - hub size 148x12mm

**Blackbird Junior** - hub size 142x12 (till 2021, since 2022 change for 148x12 mm).

## Blackbird, Bluebird and Blackbird Junior deraillieur hanger



Axle frame M12x1.75 with a lever for the hub spacing 142x12 mm or 148x12 mm. The frameset includes an axle without a lever. An option with a lever can be purchased separately.



An instructional video showing how to install deraillieur hanger to the frame [YT >>> Watch the video](#)

An instructional video showing how to assemble a suspension bike [YT >>> Watch the video](#)

## 6. SUSPENSION SETTINGS

Tutorial video showing how to set up the suspension on a full-suspension bike. [YT >>> Watch the video](#)

### INITIAL SAG

Suspension settings are a matter of personal preference. Some riders prefer a soft setup, others a hard setup. Depending on the riding style, skills, and conditions on the route. The suspension on a trail/ enduro bike works fine with approximately 20% -30% initial sag. For the front shock, the value of 20-25% should be assumed, while for the rear shock the initial deflection should be about 25-30% of the total stroke. Before starting work, set the return damping to the fully open position.

To measure the SAG, follow the instructions/indications below:

- Move the O-ring on the stanchion so it touches the fork seal, the same for the rear shock
- Stand on the pedals with your full body weight with full equipment: protective armor, helmet, neck protector, water bottle or water bag, etc. It is important that the equipment and clothing reflect the real riding conditions to give the most accurate results. While standing on the bike, bend the suspension several times, then push the O-ring against the shock seals again. It is best to have someone to help, but you can deal with it yourself, for example by leaning against the wall of the building.
- Get off the bike carefully and measure the SAG with a ruler or tape measure printed on the stanchion, or ask someone to read the value on the scale when standing on the bike in a neutral position (slightly bent knees and hands in elbows). Inflate or deflate the damper until the desired deflection of the shock is achieved.

In the case of an ungraduated rear shock, to determine the percentage of initial deflection, its total deflection must first

be measured, because it is shorter than those given in the catalog for the total travel of the rear swingarm. To do this, reduce the pressure in the air chamber so that you can bend the shock to its extreme position, then inflate it and measure the distance between the O-ring and the seal. For example, a bicycle with 160mm travel has a rear shock with 70.87mm deflection, assuming a SAG of 30%, its value measured on the shock absorber piston with correctly set pressure should be 21.26mm ( $70.87 \times 0.3 = 21.26\text{mm}$ ).

### REBOUND – return damping (rebound speed)

In the damper return damping setting, the so-called „curb test” works best. To proceed with the adjustment, follow the instructions/indications below:

- Unscrew the Rebound valve to the extreme position, depending on the manufacturer on the casing towards the „bunny” symbol, „Fast” or minus sign. There is no return damping in this position.
- Find a less traveled road in your area with a medium size curb.
- While sitting in the saddle, without using the brakes, slowly descend from the saddle. The damper piston retracts first, then returns to its original position and begins to oscillate until it stops.
- To counteract the “rocking” phenomenon, turn Rebound two clicks towards the “turtle” symbol (+; “slow”) and repeat the test by rolling off the curb. By adjusting in this way, you should observe the moment when the damper stops oscillating after a rebound.

- The resulting setting is the initial setting from which you should start. Further adjustments for two clicks backward or forwards can be made on the trail depending on riding conditions and preferences.
- Remember that, as with the SAG, the return suppression is determined by the weight of the user and all equipment. The greater the weight of the bike user, the greater the damping will be needed to absorb the rebound energy.

**It is best to set the front shock return damping as follows:**

- Start by unscrewing the damper to the extreme position as it was in the case of the damper. Stand next to the bicycle, depress the shock as far as possible, and release it vigorously. Observe that the front wheel is clear of the ground. Increase the damping by two clicks by using the adjuster on the bottom of the right shock leg, turning towards the „turtle” symbol („+”; „slow”).
- Repeat this process until the wheel stops springing off the ground. The basic setting obtained in this way can be corrected on the trail depending on the driving conditions and individual preferences.
- Finally, get on the bike and on a straight road, vigorously bending the suspension, check that the front and rear work evenly. By pressing the suspension in this way, bend it in the range of 80-90%, if it is difficult, it may turn out that the shock or damper needs to be adjusted in terms of the air chamber capacity. To do this, contact an experienced service provider who will adjust the size of the chamber with the help of tokens.

## **COMPRESSION – speed of compression (deflection)**

Most air shocks have a compression speed damping adjustment implemented by a single knob. It enables smooth or gradual regulation until the shock is blocked. This adjustment is most often used while driving, adapting the shock to the type of route. The fully open position is most often used when descending on uneven terrain when we want the best traction. Slowing down the compression speed to about half of the range is used in normal riding on flat sections and in the case of riding on flow routes so that the suspension does not absorb the user’s speed while riding on moguls. This setting is the most used and the most universal, also for people who like to jump on a bike. The shock absorbs energy when hitting a punch, so some riders prefer to increase compression damping. The extreme setting is the least used, most often when climbing steep climbs.

More advanced designs of the shock, mount a damper with two regulators, fast and slow compression. Slow compression damping acts on the first half of the shock travel, mainly when braking, negotiating steep descents, rides, or moguls. Increasing it improves the efficiency of pedaling, prevents „swinging” and reduces the collapse of the suspension when overcoming the above-mentioned elements. Similar to the case when you have only one compression knob. Therefore, the adjustment is made in the same way.

High-speed compression damping affects the second half of the stroke of the shock from the middle of the deflection to the moment of compression. Typically, less experienced riders do not use this adjustment and it remains in the open position. Users who like to ride more aggressively, forcing the suspension to work quickly, af-

ter hitting a large obstacle will feel that the suspension dives too quickly to the end of the stroke, they can counteract this phenomenon by increasing the damping of quick compression.

A mountain biker is riding through a forest at sunset. The rider is wearing a white jersey and a helmet, and is kicking up a cloud of dust. The scene is illuminated by warm, golden light from the setting sun, creating a dramatic atmosphere. The background shows dense trees and foliage, with the sun's rays filtering through the leaves.

## 7. REAR WHEEL ASSEMBLY

The Blackbird 29, „Blackbird 27.5” (from 2021), Bluebird 27.5 „and 29” and Blackbird Junior (from 2022) frames are compatible with 148x12mm hubs.

Blackbird 27.5” frames (up to 2020) and Blackbird Junior (up to 2021) are compatible with 142x12mm hubs.

To properly install the rear wheel:

- make sure that the wheel is axially aligned and that the brake disc is properly seated in the brake caliper
- put the wheel in the hooks with the chain correctly positioned on the cassette
- insert the axle 12 mm and tighten with a torque wrench to 20 Nm.



## 8. GENERAL INFORMATION

### FORK

The Blackbird is designed to work with Enduro / FR forks with a single crown and 160-170mm travel, while the Junior version is for forks with 130-140mm travel. The Bluebird is designed to work with Trail / Enduro forks with a single crown of 130-150mm of travel. Using other types of forks or a rear swingarm with greater travel can damage the frame, injure the user or even kill him.

### REAR SHOCK

Blackbird from the 2021 season is designed to work with Enduro / FR shocks measuring 230 x 65 mm, while until the 2020 season the frame was compatible with 216 x 63 mm (8.5 x 2.5 ") shocks. From the 2020 season, Bluebird is designed to work with Trail / Enduro shocks (210 x 50 mm), and until the 2019 season with 190 x 51 mm (7.5 x 2.0 ") shocks. Blackbird Junior is compatible with 165 x 38 mm (6.5 x 1.5 ") shock absorbers. Using a different type of damper, a damper of a different length, can damage the frame, injure the user or even kill him.

### HEADSET

The Blackbird and Bluebird frames feature a tapered headstock for the IS42 / IS52 headset (bottom: 52mm inner diameter/top: 42mm inner diameter). The frame will fit forks with standard 1-1 / 8 "steerer tubes or 1.5 - 1-1 / 8" tapered steerer tubes. Importantly, you should not cut the steerer too low. The process of assembling the rudders in the frame should be performed by a qualified mechanic.

### BOTTOM BRACKET

The frame is designed to work with a BSA / ISO73 bottom bracket only and accepts conventional threaded outer bottom brackets such as SRAM GXP, Shimano BB73, or FSA MegaExo. Before installing, make sure the bottom bracket shell is clean, lightly greased, and free from dirt and paint. The installation process should be carried out according to the instructions of the cartridge manufacturer.

### SPROCKET SIZES

The frame is designed to work with the 34T sprockets. The maximum size of the sprocket is indicative only. May vary by manufacturer, model, cranks, and bottom bracket used.

### TIRES

Blackbird 29 ", 27.5" and 26 "JR are compatible with tires, with a maximum size of 2.5". Bluebird works with tires with maximum dimensions of 2.4 „for the 29" version and 2.8 „for the 27.5" version. Note that these numbers are indicative as the size and shape of the tires may vary depending on the manufacturer and the width of the rim on which it will be mounted.

### BRAKE COMPATIBILITY

The Blackbird 29 "and 27.5" and Blackbird Junior brake mounts are Post Mount 160 compatible. The Blackbird 29 "and 27.5" maximum brake disc size is 203mm and the Blackbird Junior is 180mm.

### SEATPOST AND SEATPOST CLAMP

The frame works with 30.9mm seatposts. Internal armor routing for dropper posts is available. Do not extend the seat post above the minimum extension mark. The diameter of the clamp on the seat tube is 34.9 mm.

**WARNING:** It is important to make sure the rear tire does not touch the saddle when the suspension is at its maximum travel. To check this, you must fully deflect the rear suspension without the spring mounted on the rear shock absorber.

## 9. TIGHTENING TORQUE

Correct tightening of the bicycle fasteners, nuts, and bolts are essential. Too little force and the fastener may not hold securely. Too much force and the fastener may tear, stretch, distort or break the thread. Either way, incorrect torque can damage the component, which can cause you to lose control and fall. In case of doubt or problems found during your test ride, seek immediate advice from a professional bicycle mechanic.

See the instructions of the suppliers of the suspension fork, rear shock, and other parts that come with this frame. Do not use the bicycle until all problems have been resolved. Riding a bicycle with any defects may be dangerous to health and life. If you are not a qualified bicycle mechanic, do not make any of these adjustments yourself and seek advice from your local bicycle dealer.

The rear suspension bolts (rear shock and pivots) have been tightened at the factory to the specified torque. If you re-adjust, take particular care when re-tightening. **DO NOT** lubricate any of the pivot points. The factory uses high-quality self-lubricating Teflon.

Tightening torques (Nm) for individual points on the frame:

- rear shock mounting: 10-12 Nm
- suspension system bolts: 10-12 Nm
- rear wheel axle: 20 Nm
- rear brake mounting: 10 Nm
- derailleur hanger: 20 Nm
- seat post clamp: 6 Nm
- Remaining tightening torques:

**PDF >>> [Open the document](#)**

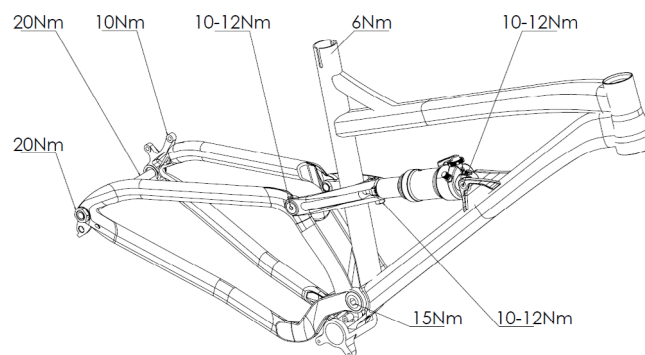

### ACCESSORIES:

The rocker arm neoprene tube protector should be wrapped together with the rear derailleur cable to protect the rocker arm from chain impacts.

A self-adhesive set of protective films can be used for additional protection of the downtube.

Before applying the protective film to the frame, degrease and clean its surface.





## 10. EXTERNAL CABLE ROUTING

The outer protector should be secured with zip ties to the top of the lower tube, inside the shock cage. For both Blackbird and Bluebird frames, the brake cable should run along the chainstay and then along the swingarm on the opposite side of the drive to the brake caliper. The rear shock must be removed for this operation. For the Bluebird, the rear derailleur shell should be routed directly along the chainstay and then towards the drive end rocker tube to the derailleur.

## 11. INTERNAL CABLE ROUTING

The Blackbird frame has the option of routing the cables inside. On the left side, there is a grommet for inserting the rear derailleur casing. The routing ends at the bottom bracket of the front triangle, then runs outward along the lower rocker tube. Additionally, with the same grommet, it is possible to insert the dropper post cord.

There is also an option to route the Seatpost cable to the outside of the frame along the brake cable over the top of the chainstay. To guide the seat post cable inside the seat tube, the frame has a hole around the center of the bottom bracket (viewed from below).

The Bluebird frame has no internal cable routing. All cables are routed through the top of the triangle head tube. The frame has only a grommet for inserting the dropper post cable into the lower part of the seat tube from the damper side. Unlike the Blackbird, the mount for the brake cable and rear derailleur shell to the control arm on the Bluebird is at the top of the swingarm.

**BLACKBIRD** 27.5" and 29"

**BLACKBIRD** JUNIOR

- Rear derailleur cable
- Dropper post cable
- Rear brake cable (always routed outside)



Outer cable housing routing (optional): Dropper post cable:



Cable Installation Tips:

**BLUEBIRD** 27.5" and 29"

External armor guidance:

- Rear derailleur cable
- Dropper post cable
- Rear brake cable (always routed outside)

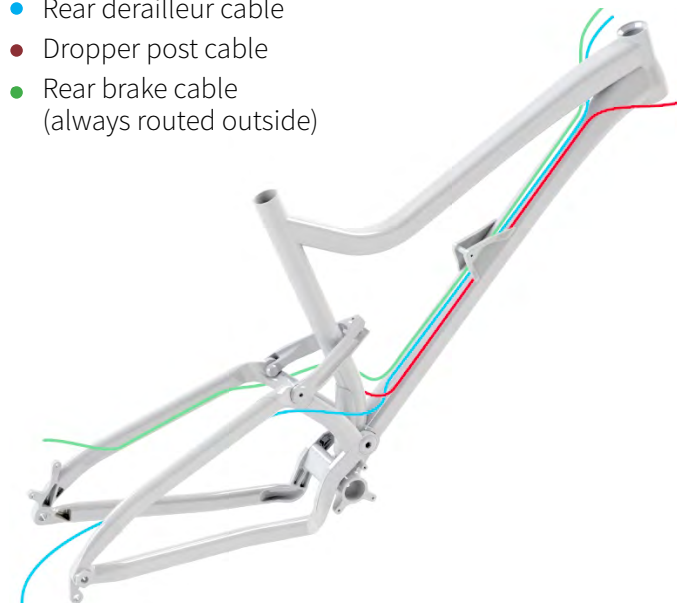

## 12. MAINTENANCE & SAFETY CONTROLS

### Do not ride the bike if any defect is noticed.

It is recommended that the user take care of the frame of his bike, which will allow him to enjoy it for a longer period. Before each ride, the bicycle should always be inspected, which should include the following points:

- clean the frame - remember that high-pressure washing may damage some parts of the bike, so avoid it,
- **carefully** inspect for signs of potential failure including cracks, corrosion, dents, paint peeling, and any other signs of potential problems and misuse.
- If you find anything suspicious, contact your local bicycle dealer for a proper checkup. These are very important safety checks to prevent accidents, injuries and shorten the life of the product.

### Points/things to check before each ride:

- That all frame bolts are properly tightened - see **#tightening torque**.
- Connecting the wheels to the frame and fork - is crucial for the user's safety.
- If axles are bolted, they must be properly tightened to the manufacturer's specifications.
- If there is a quick releaser, ensure that it is in the CLOSED position with the appropriate resistance level.
- The steering system includes handlebars, stems, headsets, and a fork. All elements should be properly twisted to ensure safety while riding. If the user wants to make any changes, be careful as incorrect settings can be very dangerous. It is always best to seek professional advice in this regard. Check that there is play in the rudders, the connection of

the stem to the handlebars and the connection of the stem to the steerer tube, the connection between the handlebars and the stem, try to lift the handlebars up and down - there should be no movement between the two. Check that there is no additional slack in the controls (stand next to the bike, tighten the front brake and push the bike back and forth. There should be no play between the frame, and the fork). If there is any play, contact your local bike shop. Do not make any adjustments yourself, unless you are sure of your abilities. Adjust the steering according to the instructions from the manufacturer of the headset. All parts of the stem should be regularly checked for damage or cracks. If a user finds anything suspicious, they should immediately contact an experienced bicycle mechanic. A damaged steering system can cause serious injury or even death.

- Connecting the bottom bracket to the frame. There should be no play between the frame and the carriage.
- The connection between cranks and the bottom bracket.
- Connecting the pedals to the cranks.

### Points/things to check before each ride:

- Linkage of the derailleur to the frame - make sure that it functions properly before each ride.
- Attach the brake caliper to the frame and fork.
- The general condition of the front and rear shock (pay particular attention to any cracks, or deformation).
- Air Shock pressure (in the case of air forks). See **#suspension settings** and manufacturer's manual. Make sure the SAG does not exceed a reasonable limit. Make sure the air pressure does not exceed the limits provided by the damper / fork manufacturer.

- Clean the tubes of the rear shock and fork.
- Brake cables and their housing for kinks, rust, broken bands, or frayed ends. If any damage is noticed, the cables should be replaced immediately. Damaged cables can seriously affect braking performance.
- Be sure to follow the manufacturer's instructions for servicing the shock absorber and other parts. Instructions for the use of additional parts are provided in the box.



## 13. LIST OF COMPONENTS

- frame
- axle
- set of cable inserts
- technical instruction

DART  
MOOR